

WRP Series

INSTALLATION
OPERATION
MAINTENANCE

- Non Ex
- Zone 1 Internal / 1 External 



MODELS:
WRP2500
WRP3100

Table of content

Page	Chapter	
3	1	Introduction
3	1.1	Declaration of Conformity
4	1.2	Declaration of Conformity Ex Zone 1/1
5	1.3	Explanation of warning symbols
5	1.4	Field of application
5	1.5	Disposal
6	1.6	ATEX Directive 2014/34/EU 2014/34/EU
7	2	Technical data
7	2.1	Specifications metric
8	2.2	Specifications U.S. Imperial
9	2.3	Dimensions
10	2.4	Dimensions with accessories
11	2.5	Connections
12	2.6	Manifolds
12	2.7	Manifolds
13	2.8	Handling and transport
13	2.9	Draining before storage
14	3	Design of a system
14	3.1	Standard system
15	3.2	Additional cooling by a tube heat exchanger
16	3.3	Additional cooling by a fan cooler
17	3.4	System layout and how to build an ATEX Zone 1/1 system
18	3.5	Safety system
19	3.6	Draining in general
19	3.7	Draining for winterization
19	3.8	Draining ATEX pumps - Important actions
20	3.9	Water separator and water tank
21	3.10	Water tank placement
21	3.11	Water consumption schedules
21	3.12	Water evaporation
21	3.13	Water requirement
22	3.14	Primary shut off valve
22	3.15	Non-return valve
22	3.16	Rotating or warm parts must be covered
22	3.17	Cell ventilation intercooler
23	3.18	Cavitation mitigation
23	3.19	Suction filter
23	4	Installation and start-up
23	4.1	Securing the pump
24	4.2	Connection to the vehicle
24	4.3	Transmission
25	4.4	Earth connection requirements
25	4.5	Direction of rotation
25	4.6	Prior to start-up
26	5	Operation and maintenance
26	5.1	Inspection and lubrication of bearings
26	5.2	Visually Inspecting for leakage
27	5.3	Check grease cartridges (Category 2 pumps with grease cartridges)
27	5.4	Inspection of ATEX safety device
28	5.5	Inspection and cleaning of water supply pipe
28	5.6	Calibration of ATEX safety device
28	5.7	Overhaul of pump
28	5.8	Inspection and cleaning of internal channels
29	5.9	Winterization
29	6	Troubleshooting
30	7	Spare parts and tools
30	7.1	Spare parts
30	7.2	Marking and identification

1 Introduction

1.1 Declaration of Conformity



Declaration of Conformity

Annex IIA

Samson Pumps A/S
Petersmindevej 21
DK-8800 Viborg

Hereby declares that the following products:

Liquid ring pump

TM6, TM5, TM4, TM3, TM2, TM3400, TM2500, TM1700, TM1600, TM600, TM350, SLP2100, SLP2700, SLP3100, WRP2500, WRP3100

Conforms to the directive:

Machinery Directive 2006/42/EC

I hereby declare that the liquid ring pumps are in conformity with the following harmonized standards:

DS/EN ISO 12100:2011	Safety of machinery - General principles for design - Risk assessment and risk reduction
DS/EN 1012-2 + A1:2009	Compressors and Pumps - Safety requirements - Part 2: Vacuum pumps

The standards above only apply to the extent that it is relevant for the purpose of the product. The product must not be used before the complete system, which it must be incorporated in, has been conformity assessed and found to comply with all relevant health and safety requirements of 2006/42/EC and other relevant directives. The product must be included in the overall risk assessment.

Viborg, 20.02.2026

Jan S. Christiansen – Manager, Technical dept.



Samson Pumps A/S | www.samson-pumps.com | CVR.DK-27913695

DOC4044G

1.2 Declaration of Conformity Ex Zone 1/1



Declaration of Conformity

Annex IIA

Samson Pumps A/S
Petersmindevej 21
DK-8800 Viborg

Hereby declares that the following products:

Liquid ring pumps

TM6, TM5, TM4, TM3, TM2, TM3400, TM2500, TM1700, TM1600, TM600, TM350, SLP2100, SLP2700, SLP3100, WRP2500, WRP3100, OM1000, OM700, OM500, OM450, OM250

Conforms to the following directives:

Machinery Directive 2006/42/EC
ATEX Directive 2014/34/EU

Explosion protection as follows on nameplate:

 II 2G Ex h IIC T4 Gb Internal

 II 2G Ex h IIC T4 Gb External

I hereby declare, that the machine are in conformity with the following harmonized standards:

DS/EN ISO 12100:2011	Safety of machinery - General principles for design - Risk assessment and risk reduction
DS/EN 1012-2 + A1:2009	Compressors and Pumps - Safety requirements - Part 2: Vacuum pumps
DS/EN 1127-1:2019	Explosive atmospheres - Explosion prevention and protection - part 1: Basic concepts and methodology
DS/EN ISO 80079-36:2016	Explosive atmospheres - Part 36: Non-electrical equipment for explosive atmospheres - Basic method and requirements
DS/EN ISO 80079-37:2016	Explosive atmospheres - Part 37: Non-electrical equipment for explosive atmospheres - Non-electrical type of protection constructional safety "c", control of ignition sources "b", liquid immersion "k"

The standard above only applies to the extent that it is relevant for the purpose of the pump. The product must not be used before the complete system, which it must be incorporated in, has been conformity assessed and found to comply with all relevant health and safety requirements of 2006/42/EC and other relevant directives. The product must be included in the overall risk assessment.

ATEX Conformity Certificate Number ExVeritas 19 ATEX 0582

Viborg, 20.02.2026

Jan S. Christiansen – Manager, Technical dept.



Samson Pumps A/S | www.samson-pumps.com | CVR.DK-27913695

DOC4047K

1.3 Explanation of warning symbols

Important technical and safety instructions are shown by symbols. If the instructions are not performed correctly, it can lead to personnel injuries or incorrect function of the pump.



To be used with all safety instructions that must be followed. A failure to follow the instructions may result in injuries and/or incorrect machine operation



This symbol stands for safety instructions which – if they are not observed – may lead to a risk of explosion. You must therefore always follow these instructions



This symbol precedes information that refers to pumps used in a potentially explosive atmosphere and instructions related to Ex

1.4 Field of application



- Inlet of foreign objects can damage the pump
- The pump is designed exclusively to pump gases, including atmospheric air
- WARNING!
Avoid cavitation of the pump! For further information, see instruction manual for the Samson Pumps vacuum control valve (optional)

It must be ensured that the inlet gas cannot react with the water and create aggressive bonds that break down the pump's components.

For other operating data, see specifications.

The pump can only be used with media that is not aggressive to the pump's materials.

The pump may only be used with media that are not aggressive to the pump's materials. See section "Technical data" for pump materials specifications.

When using ATEX-approved pumps, refer to the marking on the pump and the areas of application specified in the ATEX Directive.

1.5 Disposal

Samson's liquid ring pumps are manufactured so that most parts of the unit can be reused or recycled.

Samson Pumps offers all users the option of returning used products for refurbishment or scrapping.

Alternatively, the customer may disassemble the pump and sort the individual components.

See the section "Technical Data" for detailed pump material specifications.

All components must be disposed of in accordance with national regulations.

1.6 ATEX Directive 2014/34/EU 2014/34/EU



Zone 1

This chapter relate to Ex Zone 1/1 approved pumps
(ATEX category 2 pumps)

Zone 1 (for ATEX category 2 pumps)

The pump may be incorporated into a larger system, if the internal atmosphere has an area classification of:

Zone 1 (for ATEX category 2 pumps)

These systems will be certified in accordance with the ATEX Directive 2014/34/EU.

For the certification to be valid, the pump must be installed as described in this manual.



II 2G Ex h IIC T4 Gb Internal
II 2G Ex h IIC T4 Gb External

ExVeritas 19 ATEX 0582

Explanation of symbols and characters used in ATEX marking:



The European Commission's mark for Ex products

II	Equipment group II (non-mining)
2	Equipment category
G	Type of explosive atmosphere (G = Gas)
Ex	Indication of equipment for use in potentially explosive atmospheres
h	Explosion protection
IIC	Gas group (explosion group)
T4	Temperature class (T4 = 135 °C / 275 °F)
Gb	Equipment protection level

2 Technical data





2.1 Specifications metric



A failure to meet these specifications may result in damage to the pump



A failure to meet these specifications may result in damage to the pump and a potential risk of explosion

General specifications	Type	WRP2500	WRP3100
Ambient temperature, operation MAX	-	55°C	55°C
Ambient temperature, storage MIN	-	-20°C	-20°C
Humidity	-	100%	100%
Intake temperature air, suction side MAX	Standard	NA	NA
	1/1 	80°C	80°C
Intake temperature water, MAX	Standard	NA	NA
	1/1 	60°C	60°C
Noise level @ 7m	-	63 db(A)	63 db(A)
Noise level @ 1m	-	80 db(A)	80 db(A)
Weight	-	202 kg	222 kg
Water volume	-	66 L	81 L
Water pipe connection, dimension	-	G 1½"	G 1½"
Water pipe connection max length	-	6 m	6 m
MAX radial load on drive shaft	-	6000 N	5900 N
Revolutions MAX	-	1600 RPM	1600 RPM
Revolutions MIN	-	800 RPM	800 RPM
Pressure MAX	Standard	1 bar(g)	1 bar(g)
	1/1 	1 bar(g)	1 bar(g)
Pressure MIN	-	150 mbar abs.	150 mbar abs.
Test pressure	-	12 bar(g)	12 bar(g)
Lubricating of bearings	Standard	Man/auto	Man/auto
	1/1 	Man/auto	Man/auto
Grease type	Manual	SKF LGHQ2	SKF LGHQ2
	Automatic	SKF LAGD 125/HQ2	SKF LAGD 125/HQ2
Casted parts	-	Aluminium	Aluminium
Rotor shaft	All	Stainless steel	Stainless steel
Rotor	All	Aluminium	Aluminium
Surface treatment	All	Hard anodized	Hard anodized

2.2 Specifications U.S. Imperial



A failure to meet these specifications may result in damage to the pump



A failure to meet these specifications may result in damage to the pump and a potential risk of explosion

General specifications	Type	WRP2500	WRP3100
Ambient temperature, operation MAX	-	131°F	131°F
Ambient temperature, storage MIN	-	-4°F	-4°F
Humidity	-	100%	100%
Intake temperature air, suction side MAX	Standard	NA	NA
	1/1	176°F	176°F
Intake temperature water, MAX	Standard	NA	NA
	1/1	140°F	140°F
Noise level @ 23 ft	-	63 db(A)	63 db(A)
Noise level @ 3.3 ft	-	80 db(A)	80 db(A)
Weight	-	445 lb	490 lb
Water volume	-	17.4 US gal	21.4 US gal
Water pipe connection, dimension	-	G 1½"	G 1½"
Water pipe connection max length	-	20 ft	20 ft
MAX radial load on drive shaft	-	1349 lbf	1326 lbf
Revolutions MAX	-	1600 RPM	1600 RPM
Revolutions MIN	-	800 RPM	800 RPM
Pressure MAX	Standard	14.5 PSI	14.5 PSI
	1/1	14.5 PSI	14.5 PSI
Pressure MIN	-	4.4 inHg	4.4 inHg
Test pressure	-	174 PSI	174 PSI
Lubricating of bearings	Standard	Man/auto	Man/auto
	1/1	Man/auto	Man/auto
Grease type	Manual	SKF LGHQ2	SKF LGHQ2
	Automatic	SKF LAGD 125/HQ2	SKF LAGD 125/HQ2
Casted parts	-	Aluminium	Aluminium
Rotor shaft	All	Stainless steel	Stainless steel
Rotor	All	Aluminium	Aluminium
Surface treatment	All	Hard anodized	Hard anodized

2.3 Dimensions

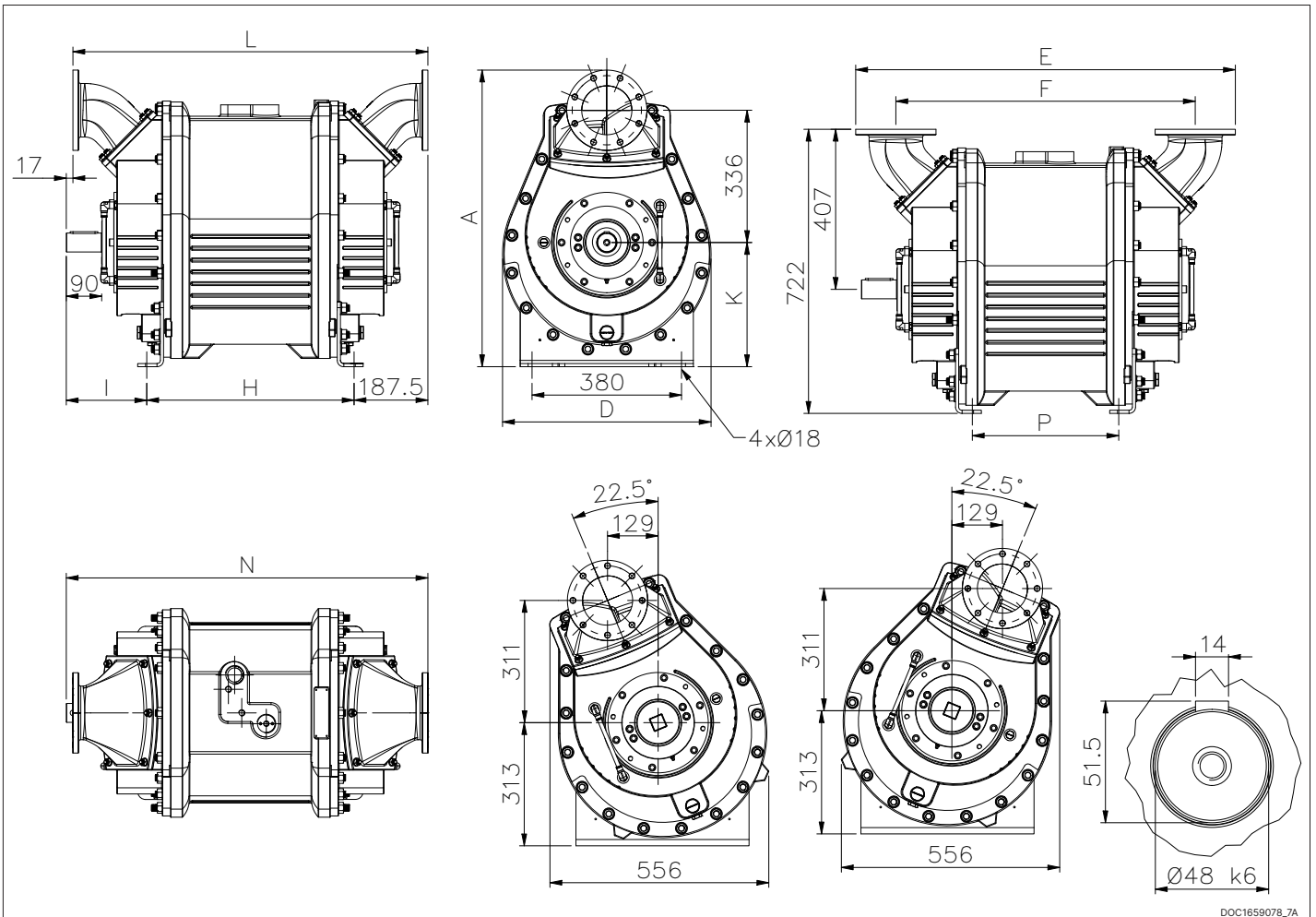

Metric	A	D	E	F	H	I	K	L	N	P
WRP2500	754	530	965	761	527	204,5	315	902	919	372
WRP3100	754	530	1071	867	633	204,5	315	1008	1025	478

Imperial	A	D	E	F	H	I	K	L	N	P
WRP2500	29,68	20,87	37,99	29,96	20,74	8,05	12,40	35,51	36,18	14,65
WRP3100	29,68	20,87	42,17	34,13	24,92	8,05	12,40	39,69	40,35	18,82

2.4 Dimensions with accessories

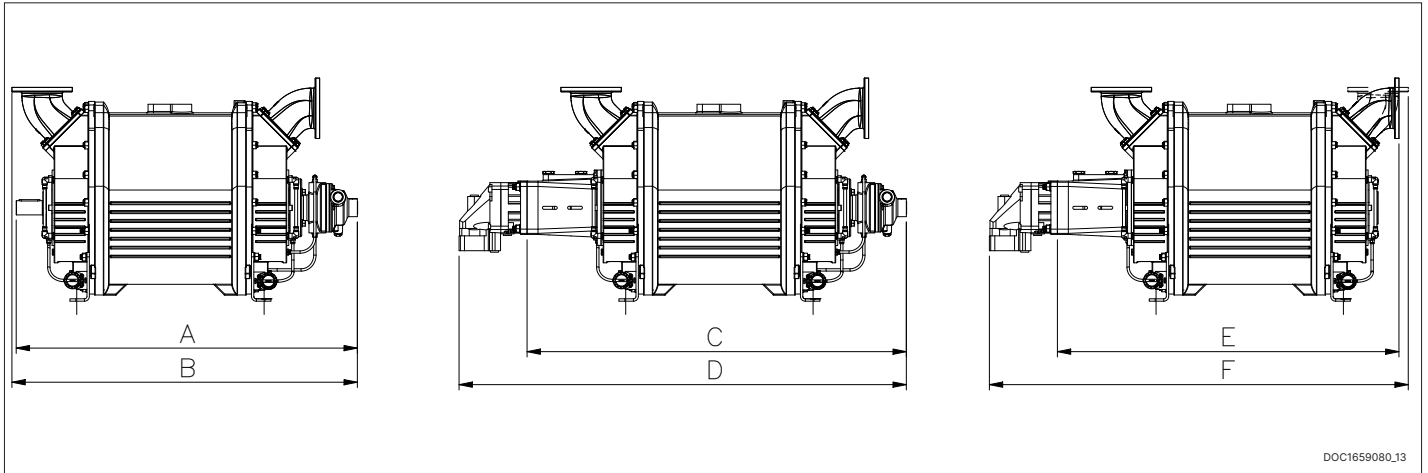

DOC1659080_13

Metric		A	B	C	D	E	F
WRP2500	ISO 90	1047	1061	1175	1390	1048	1294
	ISO 125	1047	1061	1175	1405	1048	1309
WRP3100	ISO 125	1153	1167	1281	1511	1154	1415
	ISO 162	1153	1167	1281	1560	1154	1464

Imperial		A	B	C	D	E	F
WRP2500	ISO 90	41,22	41,77	46,26	54,72	41,26	50,94
	ISO 125	41,22	41,77	46,26	55,31	41,26	51,53
WRP3100	ISO 125	45,39	45,94	50,43	59,48	45,43	55,71
	ISO 162	45,39	45,94	50,43	61,41	45,43	57,64

2.5 Connections

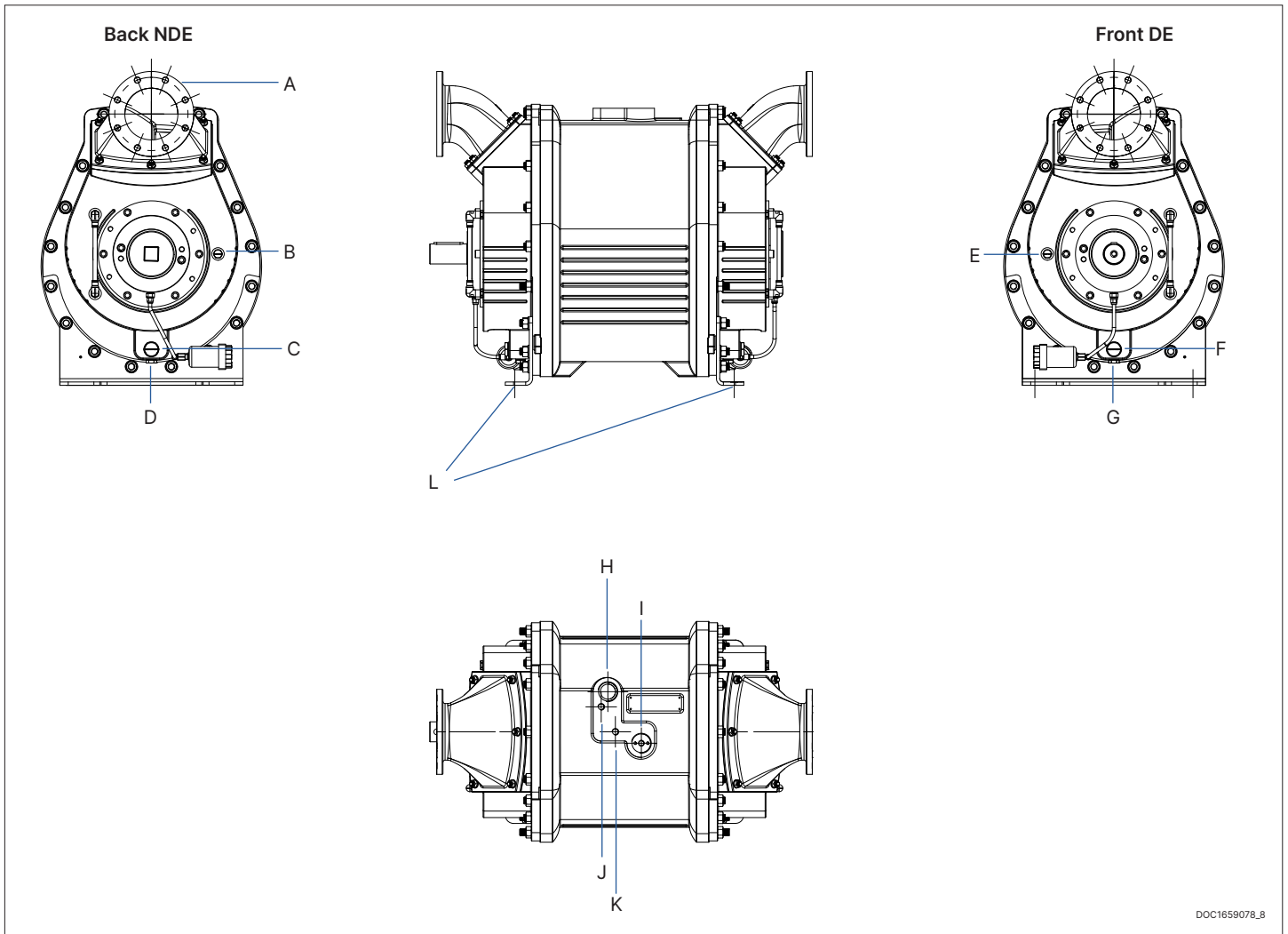

DOC1659078_8

ID	Connection	WRP2500	WRP3100
A	Truck connection	DIN28459 / DN125 / 8xØ14	DIN28459 / DN125 / 8xØ14
B	Water level monitoring (manuel or by censor)	G1/4"	G1/4"
C	⊛ Drain and winterization	G3/4"	G3/4"
D	Service access plug	G3/8"	G3/8"
E	Water level monitoring (manuel or by censor)	G1/4"	G1/4"
F	⊛ Drain and winterization	G3/4"	G3/4"
G	Service access plug	G3/8"	G3/8"
H	Intercooler	G1 ¹ / ₂ "	G1 ¹ / ₂ "
I	Water supply	G1 ¹ / ₂ "	G1 ¹ / ₂ "
J	No function	M16	M16
K	No function	M16	M16
L	Mounting	Ø18×4	Ø18×4

2.6 Manifolds

The WRP series can be configured in every conceivable way when it comes to direction of rotation, suction port placement, and manifold orientation. Use the chart below to find the correct configuration, or visit our website www.samson-pumps.com, where you can configure the WRP pump and view the corresponding product code.

Suction in drive end		Suction in non-drive end		
R1 Clockwise rotating	L1 Counter clockwise rotating	R2 Clockwise rotating	L2 Counter clockwise rotating	
				A Drive end vertical Non-drive end vertical
				B Drive end horizontal Non-drive end horizontal
				C Drive end horizontal Non-drive end vertical
				D Drive end vertical Non-drive end horizontal

DOC1638185

2.7 Manifolds

WRP2500		Vacuum-lift fluids	Air-lift fluids	Air-lift solids
	Suction hose 2"		900 RPM	900 RPM
	Suction hose 3"		900 RPM	900 RPM
	Suction hose 4"	Recomended	900 RPM	1500 RPM
	Suction hose 5"		900 RPM	1800 RPM
	Suction hose 6"		900 RPM	

WRP2500 has its best performance in 4" suction hoses and secondary in 2" and 3" with reduced RPMs.

For suction hoses above 4" we recommend this pump for vacuum lifts of fluids only.

WRP3100		Vacuum-lift fluids	Air-lift fluids	Air-lift solids
	Suction hose 2"		800 RPM	800 RPM
	Suction hose 3"		800 RPM	800 RPM
	Suction hose 4"		800 RPM	900 RPM
	Suction hose 5"	Recomended	800 RPM	1300 RPM
	Suction hose 6"		800 RPM	1500 RPM

WRP3100 has its best performance in 5" suction hoses and secondary in 3" and 4" with reduced RPMs.

For suction hoses above 5" we recommend this pump for vacuum lifts of fluids only.









2.8 Handling and transport

 A failure to meet these specifications may result in damage to the pump

The pump must be transported in such way that it is not exposed to vibrations and impacts that can overload the bearings.

The pump must be inspected for damages upon delivery. If the pump is damaged, it must not be used, and the damage must be reported to the manufacturer.

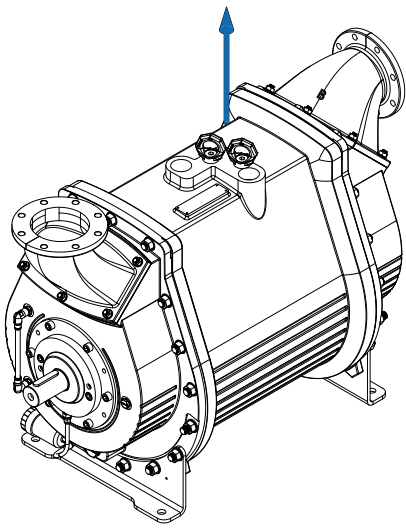
Ensure that the pump's identification plate is intact and that the marking of the pump corresponds to its use. The pump must only be handled using approved lifting eyes, in accordance with nationally applicable regulations and only in a vertical motion.

Handling & transport		DOC11093A
Road		
Sea		
Air		
Crane	<p>The pump must only be lifted using approved eye bolts in accordance with nationally applicable regulations and only in a vertical motion.</p> 	

DOC1627632

2.9 Draining before storage

 A failure to comply with the requirements for storing the pump may result in internal damage to the device

 If the temperature is below freezing point of the water, it could damage the pump. Under these conditions, the pump must be drained completely

 All plugs and protective covers must be fitted during storage

The pump's water is drained on delivery, and the pump can be immediately stored in accordance with the technical specifications. After operation, the pump can be stored for 30 days without further action. If the pump remains out of operation for a longer period of time after use, its water must be drained, and the water supply to the pump must be shut off.

Draining during normal operation, see chapter Service operation and maintenance and inspection intervals.

Drain before storage	Action
WRP2500	Use connection C or F
WRP3100	Use connection C or F

3 Design of a system

3.1 Standard system

The illustration below shows a typical configuration of a liquid ring pump installation.

The pump must be installed together with a water tank to ensure a continuous supply of operating water during operation. When the pump is started, shut-off valve (pos. 5) must be opened, allowing the pump to automatically receive the correct amount of water. The pump will immediately generate an airflow.

On the discharge side, the air and the supplied water will flow out.

The air will continue through the discharge pipe into the Samson 4-way valve. This valve determines whether the system is operating in suction or discharge mode. The position shown is suction mode, meaning the air continues out through the pipe system and into the Samson Drip Stop, which ensures that remaining water droplets and some condensate are collected and returned to the system.

If the operator stops the pump while the tank is under vacuum, a strong reverse airflow will occur in the system. In some cases, this may cause operating water to be drawn out of the pump; therefore, a non-return valve (pos. 8) should be installed on the pump's suction side. Naturally, small impurities will be drawn into the pump. For this reason, a drain valve should be installed at the bottom of the water tank.

For installation, operation, and related information, please refer to the respective product manuals and other chapters in this manual.

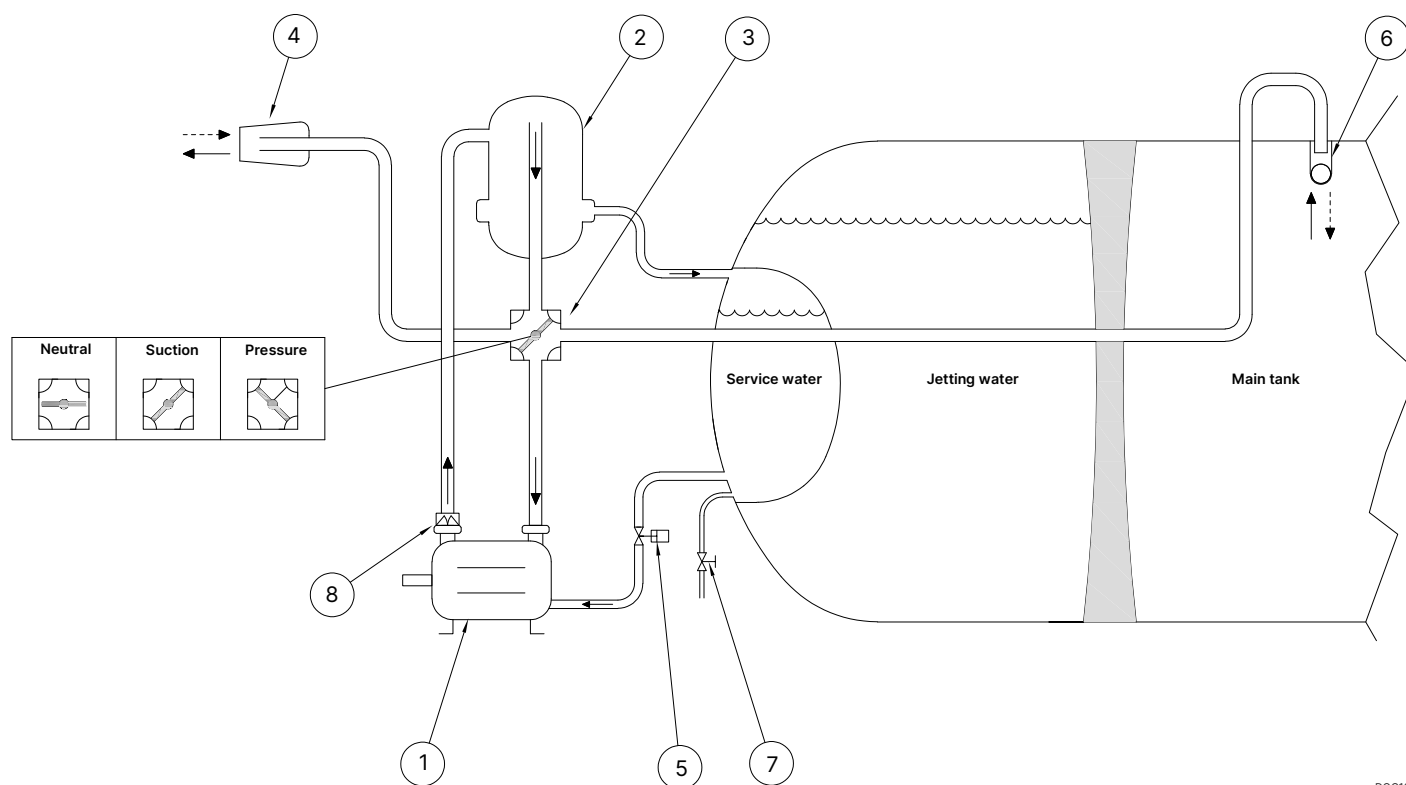

DOC1638186

Pos	Description
1	Vacuum pump
2	Water separator
3	4way valve
4	Drip stop
5	Shut-off valve
6	Primary shut off valve
7	Drain valve
8	Non-return valve

3.2 Additional cooling by a tube heat exchanger

Why?

The operating fluid is naturally cooled through evaporation and heat radiation to the surroundings. However, in some applications this passive cooling effect is not sufficient.

Cooling with jetting water through a tube heat exchanger (pos. 15) provides a simple and effective method of achieving additional cooling while requiring only minimal installation effort.

How?

The cold jetting water is used to cool the operating water via the tube heat exchanger (pos. 15). The jetting water circuit is powered by the water pump (pos. 14), while the warm circuit circulates automatically by gravity.

The tube heat exchanger (pos. 15) is supplied as a separate component. The water pump (pos. 14), however, can advantageously be supplied as an integrated unit driven by the liquid ring pump.

For detailed installation instructions, please refer to the cooling system product manual.

The need for extra cooling depends on several factors and can be assessed more accurately using Samson's online calculation tool Solution Finder, where various system configurations can be simulated and evaluated.

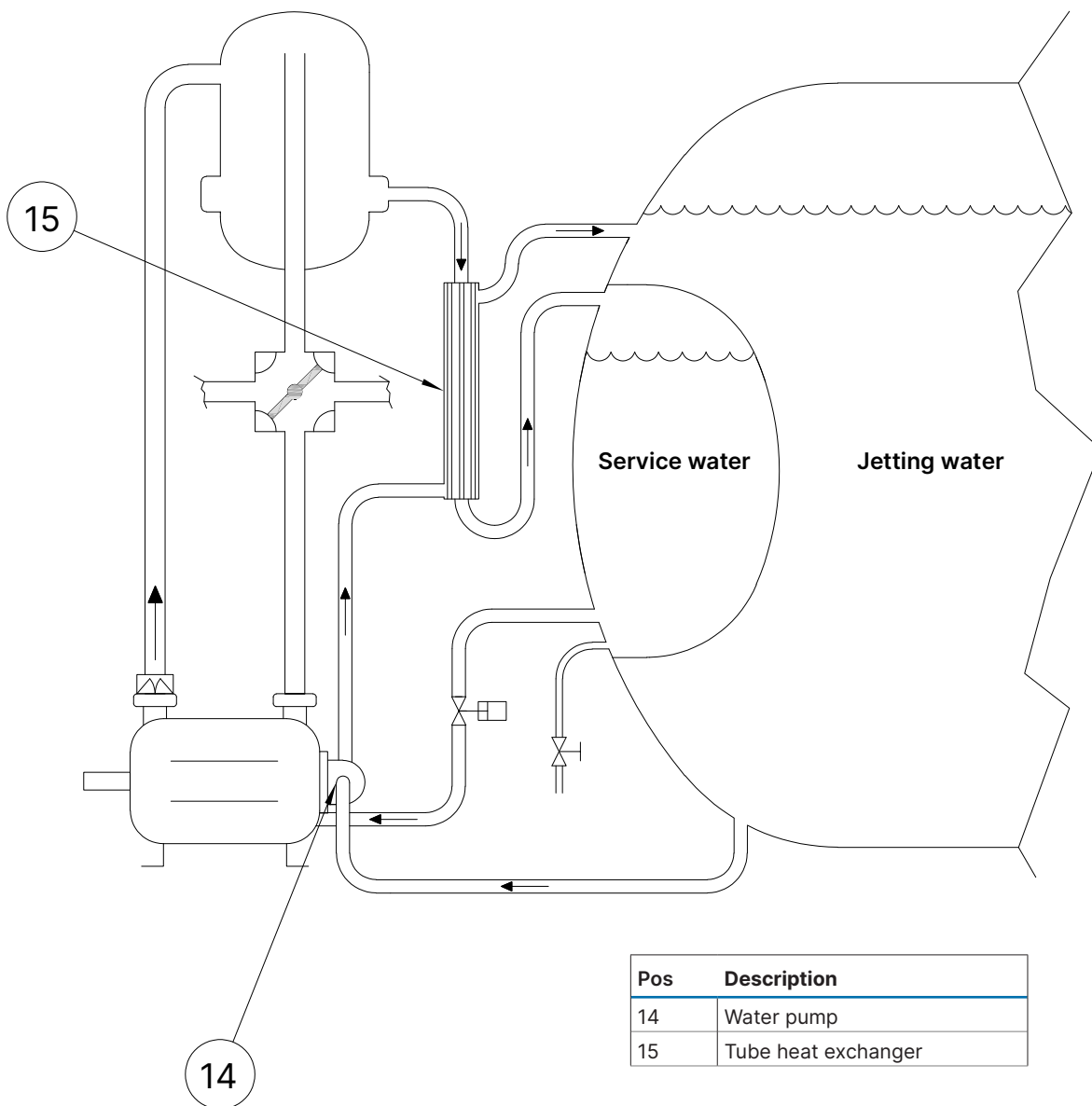

DOC1638189

3.3 Additional cooling by a fan cooler

Why?
 A secondary option for adding additional cooling is to install an air cooler (pos. 16), which is particularly relevant for vacuum vehicles that do not carry jetting water.

How?
 The cooling circuit for the air cooler is established between the top and bottom of the water tank and is driven by the water pump (pos. 14), which can advantageously be ordered as an integrated unit driven by the liquid ring pump.

For detailed installation instructions, please refer to the product manual for cooling systems.

The need for extra cooling depends on several factors and can be assessed more accurately using Samson's online calculation tool Solution Finder, where various system configurations can be simulated and evaluated.

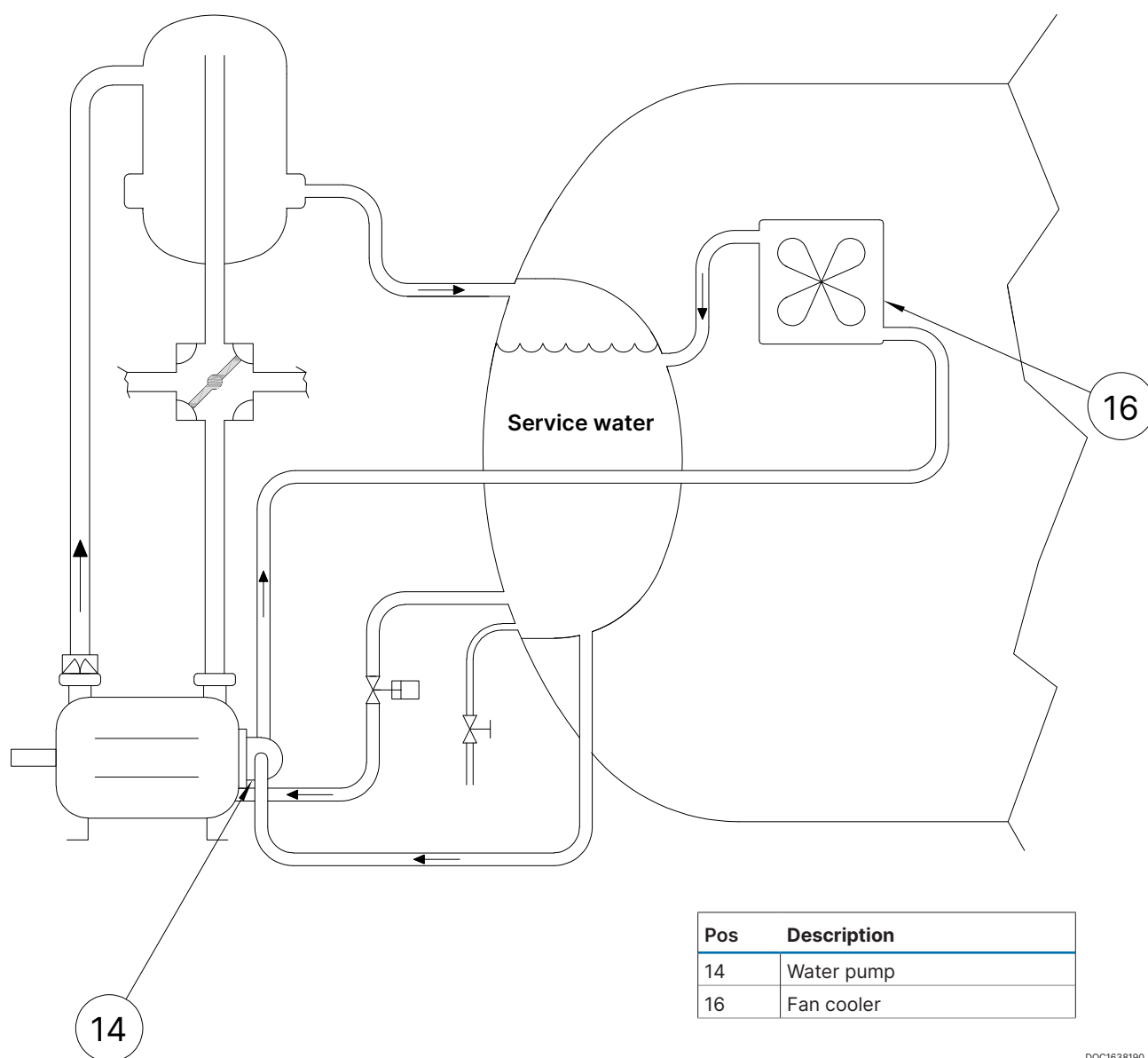

DOC1638190

3.4 System layout and how to build an ATEX Zone 1 system

Systems in zone 1 category can be build according to the fig 1638187.

The shut-off valve between the water tank and the pump (pos. 5) must be automatically operated and activated when the pump starts.

One ATEX safety device is required measuring the water minimum level in the water tank (pos. 8)

If the water level is too low, it's required that the pump is stopped automatically. The vacuum pump must be ordered for zone 1.

The ATEX safety devices required for zone 1 installation is listed below.



Zone 1
This chapter relate to Ex Zone 1/1 approved pumps (ATEX category 2 pumps)



The system must be build with the ATEX devices specified.



The maximum working pressure must not exceed specifications, by installing a safety valve

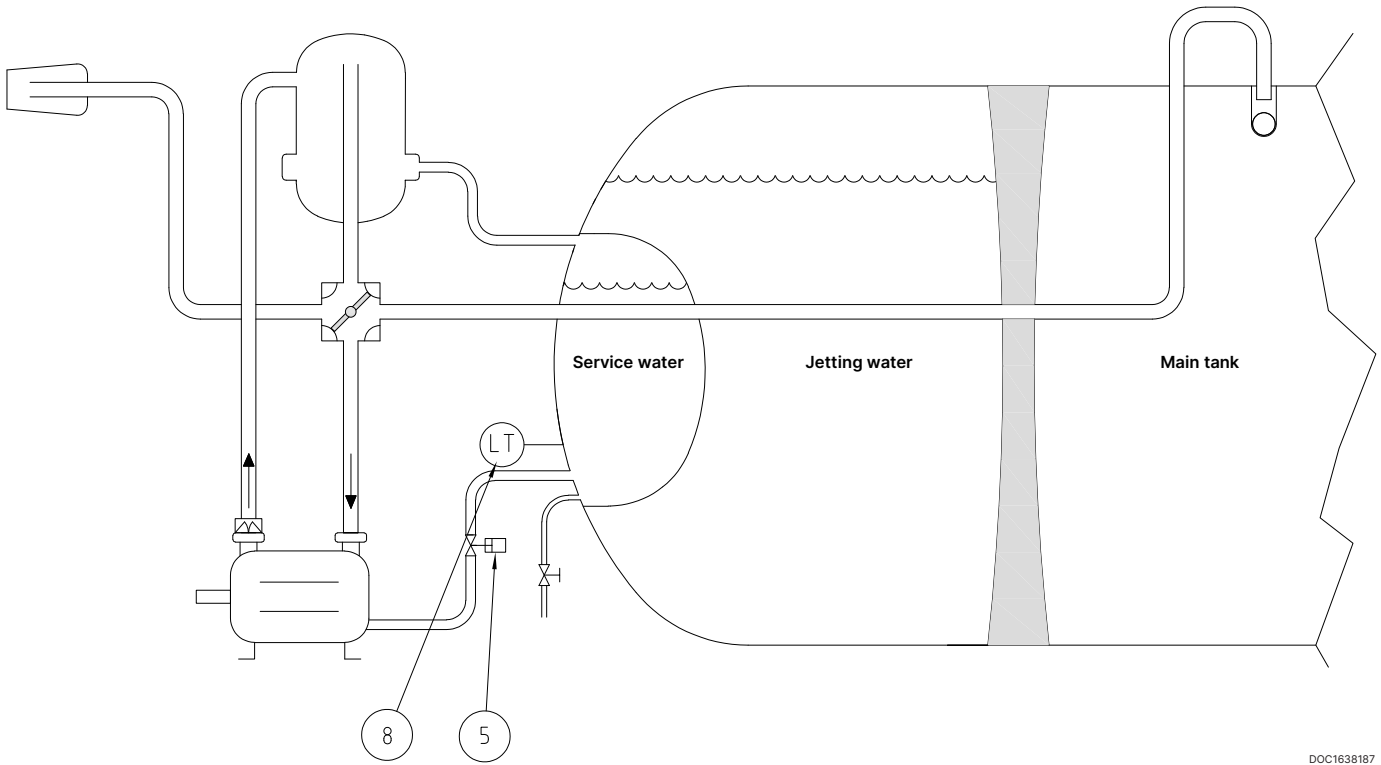

DOC1638187

Pos	Description	Safetey device	Set
5	Shut-off valve	No	
8	Level switch	Yes	Min. 50 L / 13.2 US gal

For further requirements during installation in zone 1 please look into the manual for the specific product.

3.5 Safety system

ATEX safety system must be designed in accordance to ISO 80079-37 Table E.1, shown below :

- ATEX Zone 0 Hardware Fault Tolerance 0
- ATEX Zone 1 Hardware Fault Tolerance 0

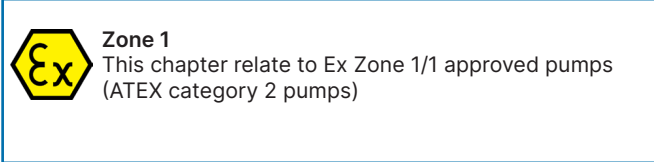

Hardware Fault Tolerance (related to effective ignition source)	2	1	0	1	0	-1	0	-1
Ignition protection type achieved by the control system (safety device)								
Hardware Fault Tolerance for the safety system	-	0	1	-	0	1	-	0
Safety Integrity Level (IEC 61508)	-	1	2	-	1	2	-	1
Performance Level (EN 13849-1)		c	d		c	d		c
Category acc. to ISO EN13849-1		2	3		2	3		2
Ignition protection type according to this standard		b1	b2		b1	b2		b1
Equipment Protection Level achieved after implementation of safety measures								
EPL Group II, III	Ga		Gb		Gc			
Zone classification	Zone 0		Zone 1		Zone 2			
NOTE 1 Hardware Fault Tolerance (HFT):								
<ul style="list-style-type: none"> • -1 indicates effective ignition source during normal operation (incendive in normal operation) • 0 indicates that the equipment under control is safe in normal operation, no effective ignition sources to be expected during normal operation. One single fault may cause the apparatus to fail so a single system is necessary to avoid ignition sources during normal operation. • 1 indicates that the apparatus is safe with one single fault. Two independent faults may cause the apparatus to fail. • 2 indicates that the apparatus is safe with two independent faults. Three faults may cause the apparatus to fail. 								
NOTE 2 SIL1 or SIL2 indicates the Safety Integrity Level of the Safety device according to IEC 61508 series. PL c or PL d indicates the Safety Performance Level of the Safety device according to ISO 13849 series.								
NOTE 3 "-" means that no Safety device is required.								

For Zone 1/1 approved pumps SIL1 or Performance Level c is required.

For Zone 0/1 approved pumps SIL2 or Performance Level d is required.

3.6 Draning in general

 A failure to meet these specifications may result in damage to the pump

Below fig. is the recommended general procedures for draining the pump.

Drain schdule		
Vehicle operating envrionment	Purpose	Frequency
Above 0°C / 32°F	Drain to clean out dirt from the pump	As required
Below 0°C / 32°F	Winterzation! Drain to prevent freezing of the service water	Before every non-operation period
Storage	Drain to protect the pump during storage	Before storage

3.7 Draning for winterzation

 A failure to meet these specifications may result in damage to the pump

Follow the instructions for each connestion in chapter "Function of connections" marked with:

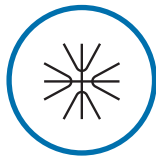

3.8 Draning ATEX pumps - Important actions

 When operating the drain valves, the outlet may contain explosive gases, corresponding to the clas-sification of the pump 's suction side

 **Zone 1**
This chapter relate to Ex Zone 1/1 approved pumps (ATEX category 2 pumps)

After draining, make sure that Zone 1/1 pumps are primed before start up.

3.9 Water separator and water tank

At Samson Pumps, we recommend using our standard water separator to ensure optimal water air separation. Each separator is precisely engineered to match the capacity of our pumps, leaving only a simple water tank design for the customer to complete.

Avoid pressure loss by placing the water separator in close range to the pump, so that the length of the outlet pipe does not exceed 3000 mm.

The service water outlet from the water tank to the pump must be positioned at least 200 mm above the pump shaft centerline. This ensures the correct influx pressure and the correct flow of water.

The water supply connection between the water tank and pump must be dimensioned as specified in specifications.

Additional information about our water separator can be found at www.samson-pumps.com, or by contacting a member of our specialist team.



Water separator must be mounted in such way that the minimum level of water is minimum 0.5 m above the pump's shaft



When operating the drain valves, the outlet may contain explosive gases, corresponding to the classification of the pump's suction side



The exhaust from the liquid separator will have the same zone classification as the pump's suction side



Zone 1

This chapter relate to Ex Zone 1/1 approved pumps (ATEX category 2 pumps)

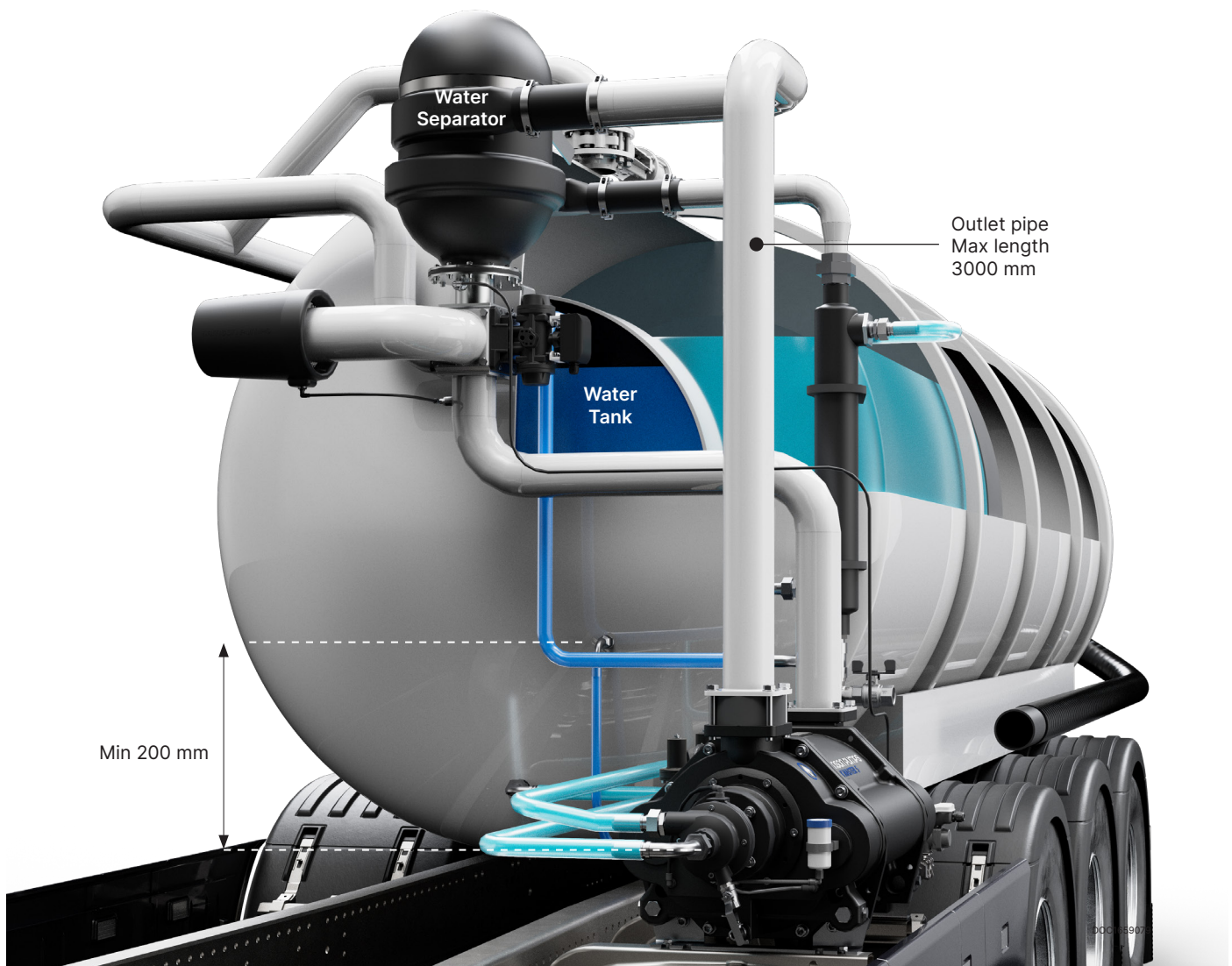

3.10 Water tank placement

There are basically three ways of integrating the water for the liquid ring pump in the vehicle structure.

1. Water inside the slurry tank

Placing the water inside the slurry tank, can be done cost effectively by welding in a second dished end.

The colling effect from the slurry and vehicle structure will be significant.

Solution Finder colling effect: 1.0

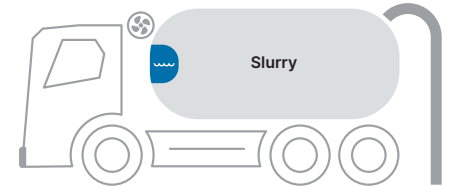

2. Water inside the jetting water tank

Placing the water inside the jetting water tank, can be done cost effectively by welding in a second dished end.

The colling effect from the jetting water and vehicle structure will be significant.

Solution Finder colling effect: 1.2

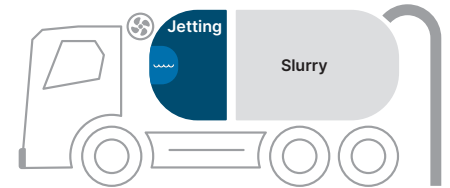

3. Water outside

Placing the water in a tank, separated from the overall vehicle-structure, will provide only a minimum of cooling effect which may require an upsized fan cooler.

Solution Finder colling effect: 0.3

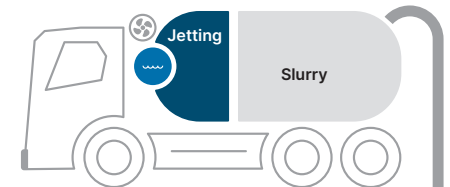

3.11 Water consumption schedules

WRP2500 metric						
Temp \ Vacuum		Choose your water temperature				
		20°C	30°C	40°C	50°C	55°C
50%	L/h	6	18	37	68	89
70%	L/h	4	11	22	41	53
80%	L/h	2	5	11	20	27
Water consumption = Liters per hour						

WRP2500 imperial						
Temp \ Vacuum		Choose your water temperature				
		68°F	86°F	104°C	122°F	131°F
50%	US gal/h	1,6	4,8	9,8	18,0	23,5
70%	US gal/h	1,1	2,9	5,8	10,8	14,0
80%	US gal/h	0,5	1,3	2,9	5,3	7,1
Water consumption = Liters per hour						

WRP3100 metric						
Temp \ Vacuum		Choose your water temperature				
		20°C	30°C	40°C	50°C	55°C
50%	L/h	7	21	45	82	107
70%	L/h	4	12	26	48	62
80%	L/h	2	6	13	24	31
Water consumption = Liters per hour						

WRP3100 imperial						
Temp \ Vacuum		Choose your water temperature				
		68°F	86°F	104°C	122°F	131°F
50%	US gal/h	1,8	5,5	11,9	21,7	28,3
70%	US gal/h	1,1	3,2	6,9	12,7	16,4
80%	US gal/h	0,5	1,6	3,4	6,3	8,2
Water consumption = Liters per hour						

3.12 Water evaporation

The water separator removes nearly 100% of the water and returns it to the water tank. However, as the temperature increases, the air is able to hold more water vapor. As a result, the relative humidity will rise and approach 100%.

This means that the air may enter the pump at a low temperature with approximately 50% relative humidity, but it will be discharged at a higher temperature and with higher humidity. Consequently, some water will be lost because due to this evaporation.

3.13 Water requirement

During operation, it is expected that minor amounts of product may enter the pump, or that the process gas may react with the service water, causing the water to become chemically aggressive. If the service water shows signs of chemical aggression, the water tank must be drained and refilled with fresh water to maintain proper operating conditions.

3.14 Primary shut off valve

The liquid ring pump is capable of handling significant amounts of liquid and solid particles in the inlet, however, it is recommended to minimize such ingress to ensure optimal pump performance and service life.

A primary shut off valve will close the suction line once the liquid level reaches the top of the main tank, thereby preventing direct liquid carryover.

In many operating conditions, foam formation on the liquid surface is unavoidable. This foam can enter the suction line before the dome valve or float valve is activated, making complete prevention challenging.

To mitigate this, a combined solution consisting of a filter and a dome/float valve as illustrated below, is recommended. The filter serves to retain foam borne particulate matter, preventing it from being drawn into the pump and reducing the risk of internal wear or performance degradation.

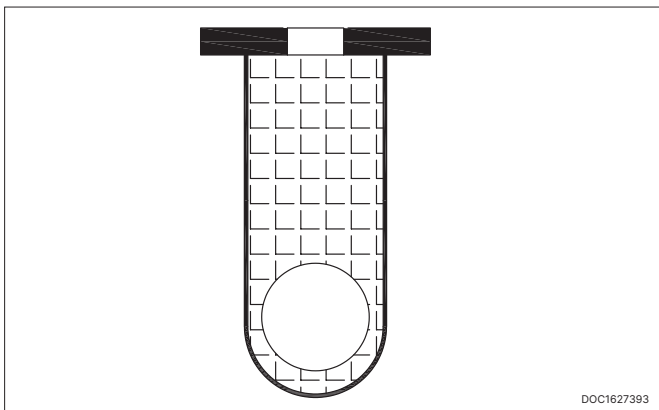

3.15 Non-return valve

When the pump is stopped with vacuum applied, the non-return valve will prevent air and water from entering back into the suction line. The non-return valve must be installed on the discharge side of the pump and immediately before the discharge flange.

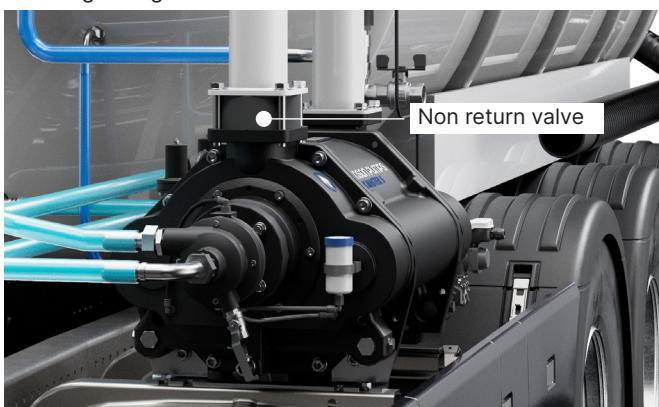

3.16 Rotating or warm parts must be covered

Rotating or hot components must be shielded to ensure they do not pose a risk of personal injury. The temperature of accessible surfaces must not exceed 80°C.

3.17 Cell ventilation intercooler

The connections A1 and C1 is connected to the discharge side of the pump below the centerline. When the pump is operating in vacuum below 400 to 500 mbar there will be vacuum in these connections.

Connecting these to the atmospheric will prevent compression inside the pump and this will cool down the liquid.

To avoid discharge its necessary to install a non return system, for example a non return valve Pos. 1 or similar.

Note:

Connections shown on a CW rotating pump. On a CCW rotating pump, the connections will be placed on the other side of the pump.

Important:

If the pump is connected to the atmospheric trough the intercooler connection, a filter Pos. 2 with maximum mesh size 2mm must be installed to avoid inlet of foreign objects.

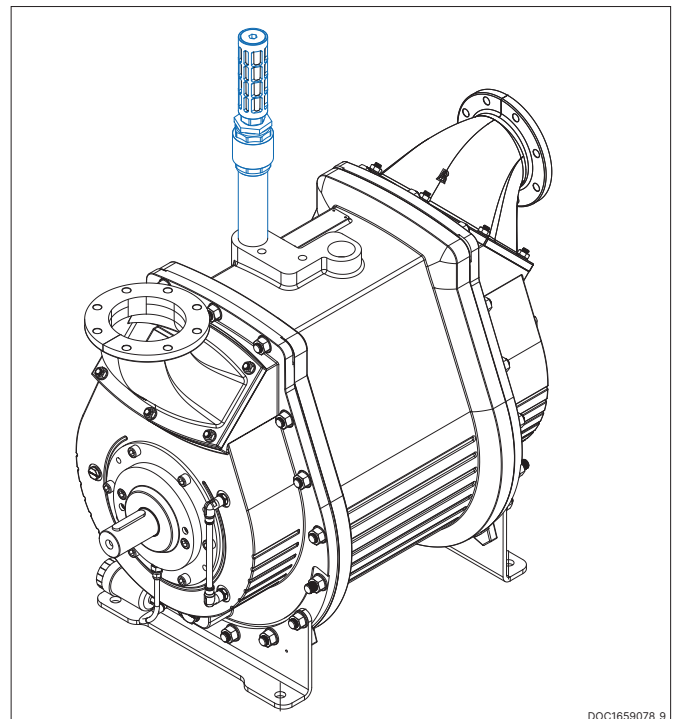

3.18 Cavitation mitigation

When the temperature reaches the boiling point of the water, steam bobbles will be created in the liquid ring. These bobbles cannot exist when they enter the discharge side of the pump and therefore, they will collapse.

The impact force on the surface of the rotor and flow plate will damage the pump and can lead to a total breakdown. It is a very harmful situation that must be avoided.

It is the combination of the pressure and the temperature that will lead to the cavitation.

Therefore, it is recommended to install a vacuum control valve, see illustration below that shows a clockwise rotating pump. If counter-clockwise rotating pump, mount in opposite manifold.

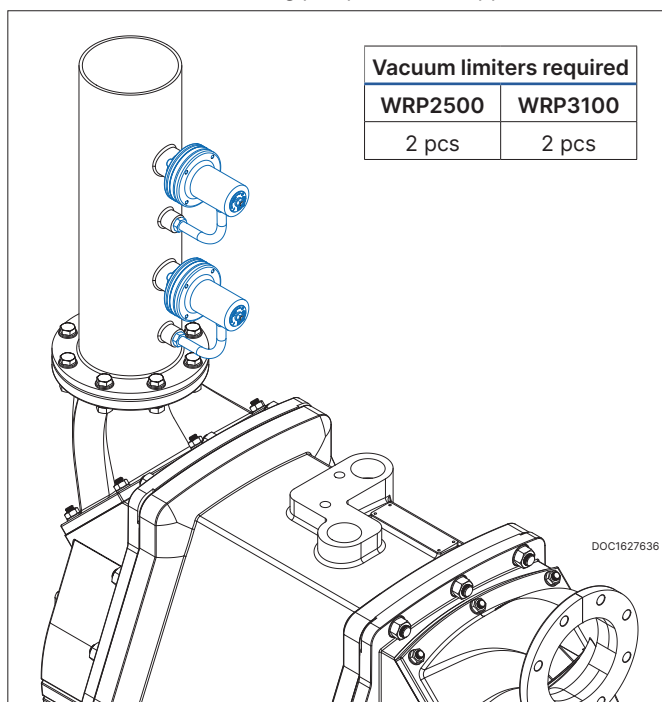

Cavitation limit schedule

Vacuum		50%	75%	80%	90%
Temperature	°C	90°	64°	59°	44°
	°F	194°	147°	138°	111°
MAX discharge temperature	°C	70°	50°	40°	30°
	°F	158°	122°	104°	86°

3.19 Suction filter



Zone 1
This chapter relate to Ex Zone 1/1 approved pumps (ATEX category 2 pumps)

In installations where there is a risk of sucking foreign elements into the pump, a filter must be mounted on the pump's suction side with a maximum mask size of 2 mm / 0.08 in.

4 Installation and start-up

4.1 Securing the pump



Installation requirements must be observed, otherwise there is a risk of damage

The pump must be installed on a stable foundation, which must be level and stable, so that the pump is not twisted or exposed to a profile distortion.

The pump must be installed with 4 pcs. M16 bolts, 2 pcs. in front and 2 pcs. in back. The bolts must be tightened to 180 Nm / 132.8 lbf-ft (A).

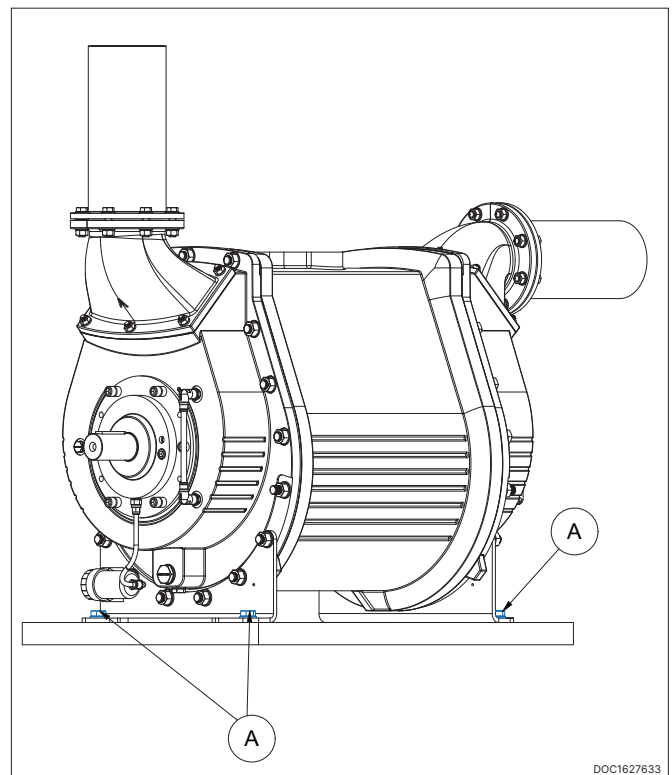

4.2 Connection to the vehicle



- Check for foreign objects in the pump and physical damage on pump
- Gaskets to be handled with highest degree of caution
- Gasket and sealing surfaces must be cleaned before assembly



External effects on the pump may lead to leakage and, as a result, a potential risk of explosion

Immediate before connecting the pipes, remove protective covers. Connection of the pump's suction and pressure pipe connections must be made with a gasket in between (C).

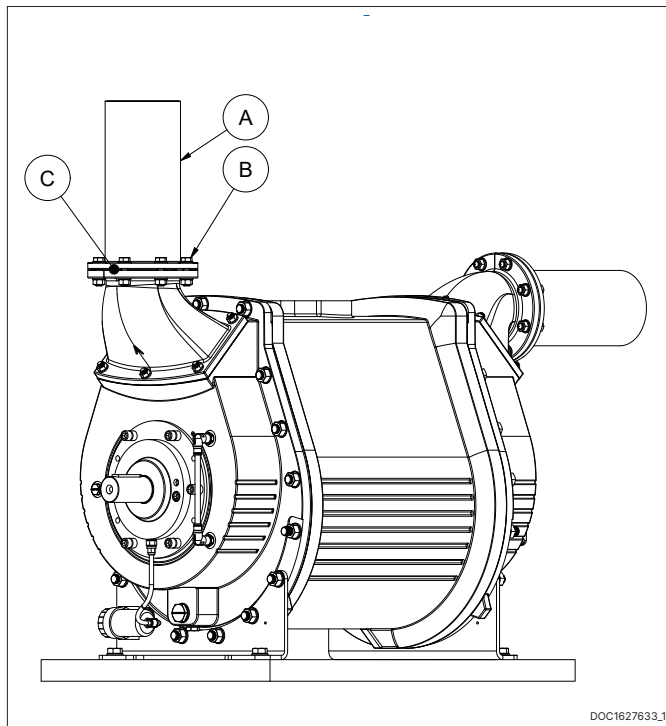

The M16 bolts must be tightened with 180 Nm / 132.8 lbf-ft (B). In order to prevent tensions in the pump, the pipe connections (A) must be tensionless while tightening the bolts.

4.3 Transmission

The pump can be connected direct or through belt transmission. For belt transmission, it must be ensured that the permissible radial force is not exceeded. See specifications.

For belt transmission, note the direction of rotation, see illustration below.

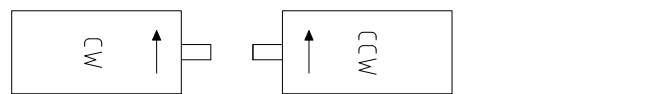
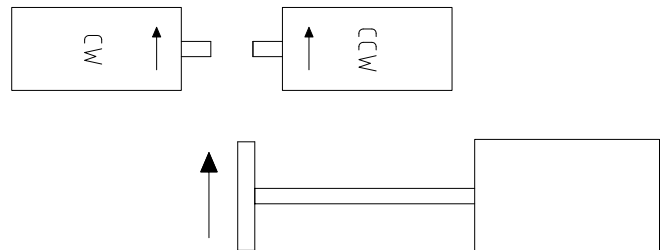
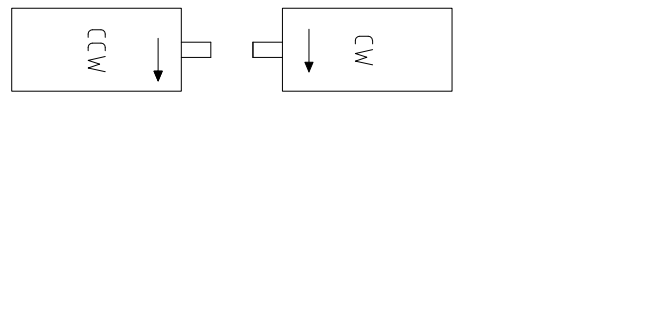
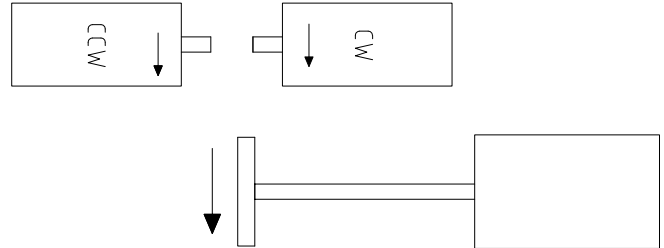

DOC1627416

4.4 Earth connection requirements



The pump must be connected to earth to prevent static electricity. Static electricity is a potential source of ignition



A failure to meet these specifications may result in damage to the pump and a potential risk of explosion



Zone 1
This chapter relate to Ex Zone 1/1 approved pumps (ATEX category 2 pumps)

The pump must be protected from the creation of sparks in connection with static electricity, in accordance with the applicable regulations for use in the current categories.

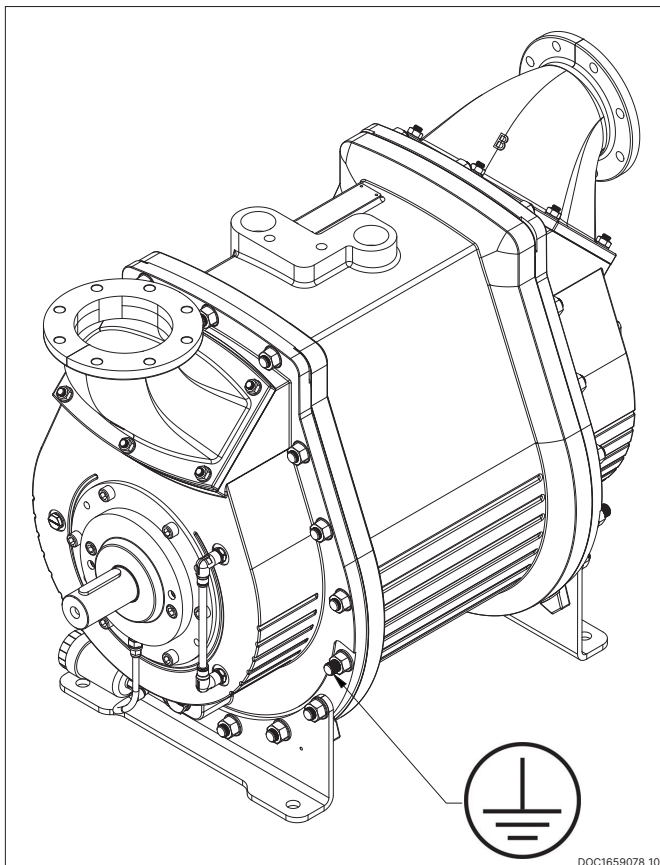

4.5 Direction of rotation

Check the direction of rotation by briefly starting the pump.

The direction of rotation of the rotor must correspond to the direction arrow!

Below left, a right-side pump is shown which has a clockwise direction of rotation (CW)

Below right, a left-side pump is shown which has a counter-clockwise direction of rotation (CCW)

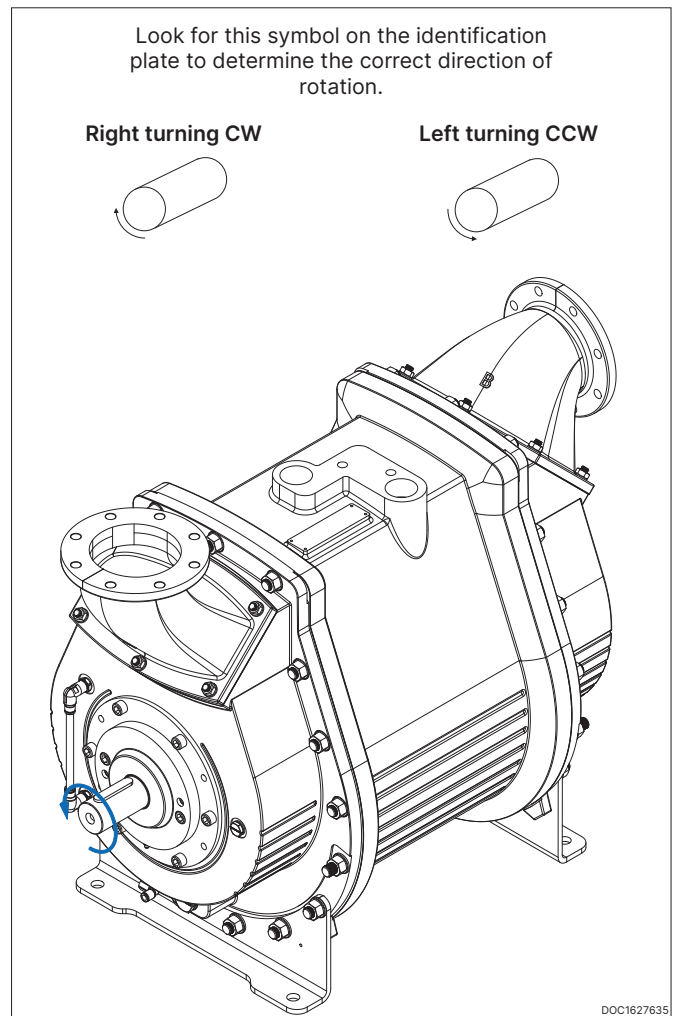

4.6 Prior to start-up



- Do not start the pump without water, as this will damage the mechanical shaft seals
- Do not start the pump if it is completely filled with water
- Do not start the pump before the grease cartridges have been activated, as this can damage the pump (if equipped)
- Stop the pump immediately if the rotational direction does not correspond to the directional arrow
- A failure to follow the above guidelines may result in damage to the pump

5 Operation and maintenance



- Check for foreign objects in the pump and physical damage on pump
- Gaskets to be handled with highest degree of caution
- Gasket and sealing surfaces must be cleaned before assembly

Section	Operation	Standard	 Zone 1/1
5.1	Inspection of bearings	Weekly	Daily
5.1	Lubrication of bearings	500 hours / 6 months ³	500 hours / 6 months ³
5.2	Visually inspect for leakage	Weekly	Weekly
3.1.3	Drain the water tank	Daily	Daily
5.3	Check grease cartridges	Weekly	Weekly
5.4	Inspection of ATEX safety device	NA	Monthly
5.5	Inspection and cleaning (if necessary) of water supply pipe	Monthly	Monthly
5.6	Calibration of ATEX safety device	NA	Annually
5.7	Overhaul of pump	NA	10.000 duty hours
5.8	Inspection and cleaning of internal channels	Monthly	Monthly
5.9	Winterization when below	0°C / 32°F	0°C / 32°F
6	Troubleshooting	As required	As required

1 -**Monitored** = Inspection must be carried out by the overall vehicle control system

2 -**Automatic** = Automatic grease cartridges is mandatory

3 -**Per 500 duty hours** = The bearings must be lubricated with grease of type SKF LGWA2, per 500 duty hours or min. once every six months, whichever comes first. Only Truck Master 4, 5 & 6. (Truck Master 2 & 3 are lifetime lubricated)

5.1 Inspection and lubrication of bearings

Bearing temperature limites		
Model	WRP2500	WRP3100
Drive end (DE)	90°C	90°C
	194°F	194°F
Non drive end (NDE)	90°C	90°C
	194°F	194°F

Bearing lubrication quantities per 500 duty hours		
Model	WRP2500	WRP3100
Drive end (DE)	40 g	40 g
	1.4 oz	1.4 oz
Non drive end (NDE)	20 g	20 g
	0.7 oz	0.7 oz

Be alert of unfamiliar sounds from bearing.

The measurements are preformed after MIN. 30 min. of operation.

If operation time is less than 30 min., perform the measurements immediately after longest period of operation.

It is recommended to lubricate the bearings while pump is running, if possible.

Over-lubrication of bearings may result in bearing damage! Do NOT exceed the amount of grease specified below!

Temperature of bearings must not exceed the permitted temperature described in system layout.

5.2 Visually Inspecting for leakage

The pump and pipe system around the pump must be inspected for leakage once a week. The inspection must be performed when the pump is both operating and idle. Any leaks must be repaired before operation may continue.

5.3 Check grease cartridges (Category 2 pumps with grease cartridges)



To prevent electrostatic discharge in hazardous areas, only wet cleaning is permitted. Appropriate measures must be taken to prevent electric discharge.



Zone 1
This chapter relate to Ex Zone 1/1 approved pumps (ATEX category 2 pumps)

If the pump is equipped with an automatic lubrication feature. It must be inspected and replaced as needed.

When the pump is commissioned for the first time, the cartridges must be activated by turning the arrow in the clockwise direction.

The cartridge is set to 12, which corresponds to an emptying time of 12 months.

The cartridge must be replaced when empty.

It is only allowed to use automatic lubricator of type **LAGD 125/HQ2**.

WPR2100 and WRP3100

Activating the grease cartridges (Accessories)

Turn the handle in NDE clockwise to position 12.
Turn the handle in DE clockwise to position 12.
The pump has been lubricated from factory and is ready to start.

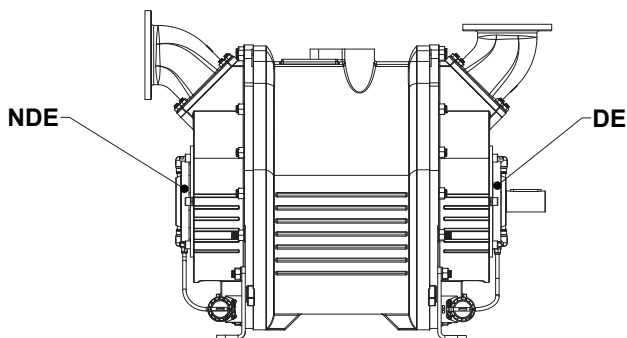

5.4 Inspection of ATEX safety device



ATEX safety device must be inspected in accordance with table to ensure proper functionality. A failure to perform the required inspections will result in the discontinuation of the pump's approval.



Zone 1
This chapter relate to Ex Zone 1/1 approved pumps (ATEX category 2 pumps)

Safety devices to be inspected in accordance with applicable regulations.

ATEX safety devices can be found in chapter "How to build an ATEX Zone 1/1 system".

5.5 Inspection and cleaning of water supply pipe

The pipe connection between the liquid separator and pump must be inspected at least once a month, and any contaminants must be removed.

5.6 Calibration of ATEX safety device



Zone 1
This chapter relate to Ex Zone 1/1 approved pumps (ATEX category 2 pumps)

Safety devices (if equipped) must be calibrated once a year in accordance with the applicable requirements. The pump may not be started before the instruments have been re-installed.

5.7 Overhaul of pump



Zone 1
This chapter relate to Ex Zone 1/1 approved pumps (ATEX category 2 pumps)

ATEX approved pumps must be serviced after 10.000 duty hours. This is done by sending the pump to Samson Pumps, or approved and certified partner, upon agreement. The pump must be cleaned before shipment.

Repairs carried out on ATEX pumps may only be performed by Samson Pumps, or approved and certified partner. If this requirement is not observed, and the pump's seal is broken, the pump's declaration of conformity is not valid and Samson Pumps is no longer responsible for any resulting consequences.

Non EX pumps has no limit of duty hours before service is required.

5.8 Inspection and cleaning of internal channels

The pump is designed with internal water channels for lubrication of the mechanical shaft seals. Remove the plugs as listed below and clean the channels using a $\varnothing 5$ mm 150 mm / 5.9 in long screw driver or similar. All connections can be identified in chapter "Connections".

Model	Connections to be cleaned	
	CW	CCW
WRP2100	D & G	D & G
WRP310	D & G	D & G

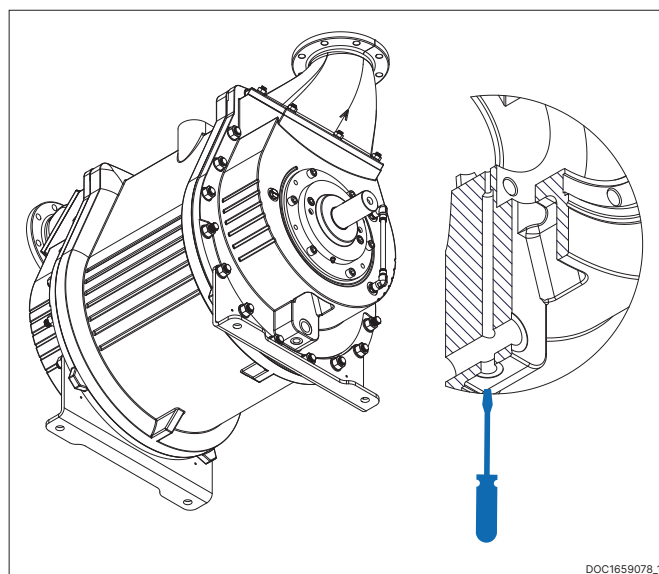

DOC1659078_11

5.9 Winterization



Installation requirements must be observed, otherwise there is a risk of damage

The following section addresses scenarios where the ambient temperature falls below the freezing point of water.

If the ambient temperature is below 0°C (32°F), there is a risk that water within the system may freeze. While ice formation will prevent the pump from operating, it will not immediately cause damage to the pump itself. This is due to the integrated Freeze-Safe inserts, which are designed to absorb the expansion of ice and thereby protect the pump from frost-related structural damage.

Important: A frozen pump must never be started. Attempting to operate the pump while frozen may result in damage to both the pump and the transmission system. If the pump has not been properly drained and water has frozen inside, it is essential to fully thaw the pump before initiating operation.

To prevent freezing-related issues, we recommend implementing one of the following anti-freeze procedures on the vehicle:

1. Drain the pump at the end of each workday and refill it immediately before resuming operation.
2. Maintain the pump and water system above freezing using a heating system, potentially integrated with the jetting water antifreeze circuit.
3. Protect the water in the pump with antifreeze fluid suitable for the system.

6 Troubleshooting

Problem	Cause	Effect	Corrective measure
The pump is unable to create a vacuum	<ul style="list-style-type: none"> • Water control valve is closed • The pump is not receiving enough water • The temperature of the water is too high 	<ul style="list-style-type: none"> • Reduced output • The pump can become damaged during cavitation 	<ul style="list-style-type: none"> • Check water control valve • Check the water supply • Stop the pump and wait until the temperature has dropped to a sufficient level, or lower the temperature
The start-up power is too high	<ul style="list-style-type: none"> • Too much water in the pump prior to start-up 	<ul style="list-style-type: none"> • Noise at start-up and possible overload of the power supply 	<ul style="list-style-type: none"> • Check the stop valves in the water supply for leakage
Noise during operation	Cavitation	<ul style="list-style-type: none"> • Severe damage to the pump and potential risk of breakdown 	<ul style="list-style-type: none"> • Increase the suction pressure or lower the temperature of the water
Leakage from the bearing housing's drain holes	<ul style="list-style-type: none"> • Damaged shaft seal 	<ul style="list-style-type: none"> • Bearings may become damaged • Potential risk of explosive gas leak 	<ul style="list-style-type: none"> • Stop the pump and contact the manufacturer

7 Spare parts and tools

7.1 Spare parts

To order spare parts, please visit the Samson Pumps Product center.

Product Center

To identify the correct Generation. Please see chapter Marking and identification

7.2 Marking and identification

