

Water Separator Series

INSTALLATION
OPERATION
MAINTENANCE

ATEX APPLICABLE



Air & Water mix inlet
Connect to pump discharge

MODELS:
Water Separator DN80
Water Separator DN100

Table of contents

Page	Chapter	
3	1	Introduction
3	1.1	Declaration of Conformity
4	1.2	Digital services
4	1.3	Explanation of warning symbols
4	1.4	Field of application
4	1.5	Disposal
5	1.6	Explanation of stamped symbols
6	2	Technical data
6	2.1	Specifications
6	2.2	Handling and transport
6	2.3	Storage
7	2.4	Dimensions
8	2.5	Function of connections
9	2.6	Performance
9	2.7	Right sizing
10	3	Design of a system
10	3.1	Mounting
10	3.2	Connection to internal pipe system
11	3.3	Placing on the vehicle
11	3.4	Welding the flange
11	3.5	Pressure conditions in the water tank during pump operation
11	3.6	Drain procedures for water separator
11	3.7	Water separator for Truck Master 6
12	4	Installation and start-up
12	4.1	Installation
12	4.2	Earth connection requirements
12	4.3	Installation on a tank tipper truck
13	5	Service operation and maintenance and inspection intervals
13	5.1	Winterization
13	5.2	Drain inspection
13	5.3	Visually Inspecting for leakage
13	6	Spare parts and tools
13	7	Troubleshooting
14	8	Marking and identification
14	8.1	ID Plate location
14	8.2	ID Plate

1 Introduction

1.1 Declaration of Conformity



Declaration of Incorporation

Annex IIB

Samson Pumps A/S
Petersmindevej 21
DK-8800 Viborg

Hereby declares that the following products:

Water Separator DN80 & DN100
Water Separator 5, -10, -20, -30, -40, -50, -60, -70, -90, -100

Conforms to the directive:

Machinery Directive 2006/42/EC
Pressure Equipment Directive 2014/68/EU

I hereby declare that the liquid ring pumps are in conformity with the following harmonized standards:

DS/EN ISO 12100:2011	Safety of machinery - General principles for design - Risk assessment and risk reduction
DS/EN 1012-2 + A1:2009	Compressors and Pumps - Safety requirements - Part 2: Vacuum pumps

When the Water Separators are ordered as Ex version, they are hazard analyzed according to the ATEX Directive 2014/34/EU with the following result:

- The Water Separator does not have a potential ignition source.
- The ATEX Directive 2014/34/EU does not apply to this product.
- The product may be used within the Ex-area when Ex marked.
- See Marking and identification in manual for Ex identification.

The standards above only apply to the extent that it is relevant for the purpose of the Water Separator. The product must not be used before the complete system, which it must be incorporated in, has been conformity assessed and found to comply with all relevant health and safety requirements of 2006/42/EC and other relevant directives. The product must be included in the overall risk assessment.

Water Separator 5, -10, -20, -30, -40, -50, -60, -70, -90, -100 must not be exposed to an operating pressure of more than 0.5 bar gauge.

Water Separator DN80 & DN100 is approved for maximum 1 bar gauge.
Water separators approved for 1 barg operation will be marked accordingly on the nameplate.

Viborg, 08.06.2026

Jan S. Christiansen – Manager, Technical dept.

1.2 Digital services

Samson Pumps offers a number of digital services to help our customers gain the best possible output from our products.

Calculate



Solution Finder

Buy



Product Center

Learn



How to build

1.3 Explanation of warning symbols

Important technical and safety instructions are shown by symbols. If the instructions are not performed correctly, it can lead to personnel injuries or incorrect function of the water separator.



To be used with all safety instructions that must be followed. A failure to follow the instructions may result in injuries and/or incorrect machine operation

1.4 Field of application



- Inlet of foreign objects can damage the Water Separator
- The Water Separator is designed exclusively to separate outlet gases from liquid ring vacuum pumps
- Comply to general specifications in chapter Technical data

The water separator is designed to separate water and air, from a liquid ring vacuum pump exhaust. This separation will not be 100%, but only partially. A minor part of the liquid exhaust will evaporate into the atmosphere and drops of liquid from the exhaust will occur as well.

The water separator must be placed in a safe position on the vehicle, without risk of collision with branches, wires or other objects that may come in its way.

1.5 Disposal

Samson's water separator is manufactured so that the whole device can be reused/recycled. Samson Pumps offer all users the option of returning used products to be restored or scrapped.

Alternatively, the water separator must be taken apart and sorted into its separate components, by the customer (see chapter "Specifications").

These components must be disposed of in accordance with national regulations.

1.6 Explanation of stamped symbols

Important product information is shown by symbols. Same symbols are used on Water Separator and Drip Stop. Description of the symbols below. From left to right.

1. The material is antistatic.
2. Date of production.
3. Material designation and recycle information.

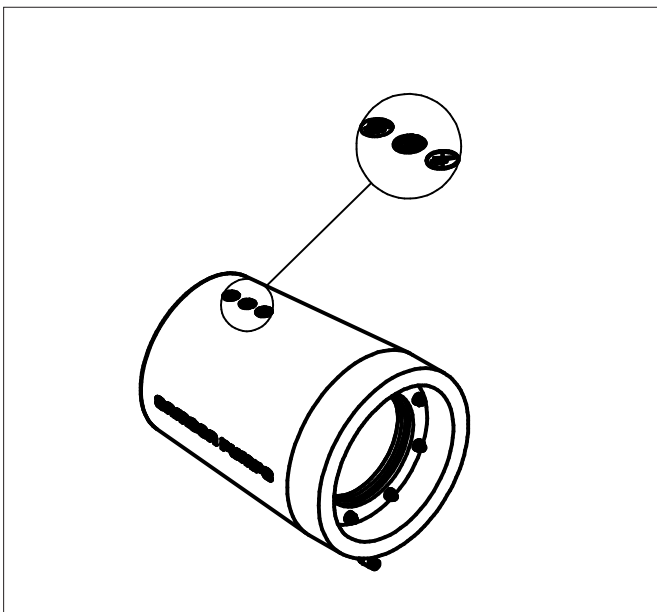
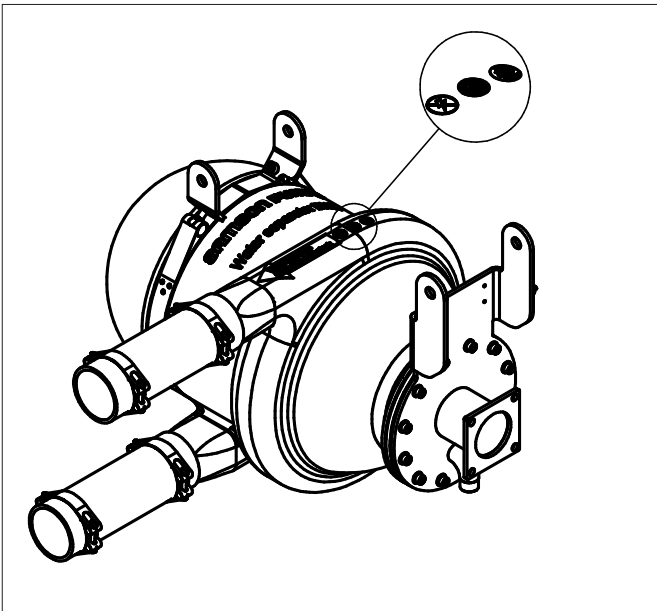
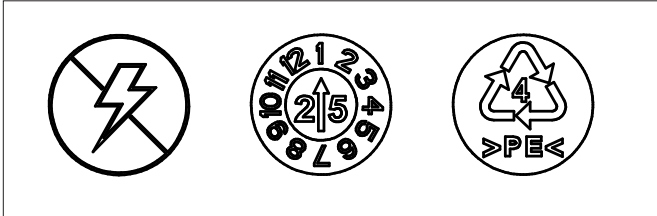

2 Technical data

2.1 Specifications



A failure to meet these specifications may result in damage to the water separator

General specifications	Water Separator DN80	Water Separator DN100
Ambient temperature, storage MAX	85°C	85°C
Ambient temperature, storage MIN	NA	NA
Inlet temperature Air & water mix, MAX	85°C	85°C
Weight	23 kg	26 kg
Volume	36 L	61 L
Pressure MAX	1 bar(g)	1 bar(g)
Test pressure	1,5 bar(g)	1,5 bar(g)
Molded parts	Cross-linked PE	Cross-linked PE
Steel parts	AISI316L	AISI316L
Seals	NBR	NBR







2.2 Handling and transport



A failure to meet these specifications may result in damage to the water separator

The water separator must be transported in such way that it is not exposed to stroke or other shock impacts that might damage product.

The water separator must be inspected for damages upon delivery. If the water separator is damaged, it must not be used, and the damage must be reported to the manufacturer.

Handling & transport	
Road	 
Sea	 
Air	 

DOC11093A

2.3 Storage

The water separator can be stored without any further actions.

2.4 Dimensions

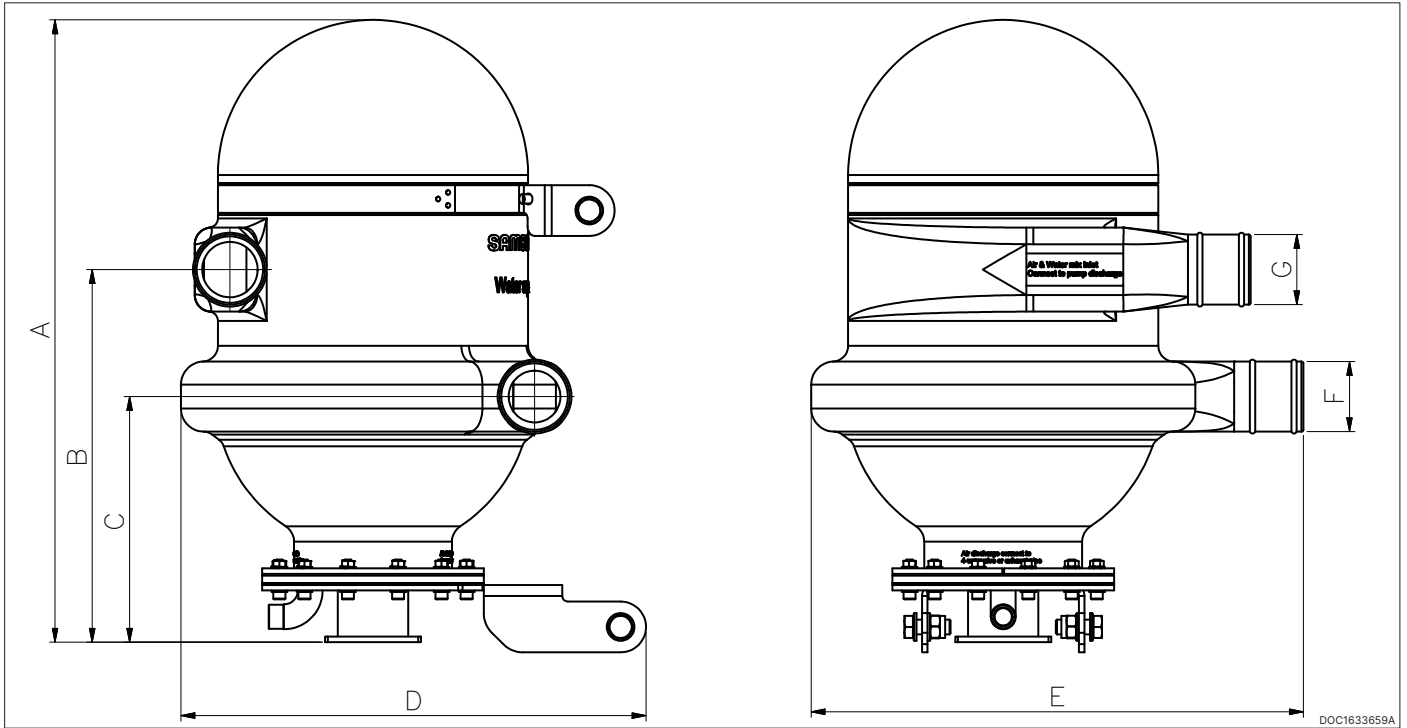

Model	A	B	C	D	E	F	G
Water Separator DN80	674mm / 26,5 in	404mm / 15,9 in	266mm / 10,5 in	504mm / 19,8 in	533mm / 21,0 in	Ø76mm / 3,1 in	Ø76mm / 3,1 in
Water Separator DN100	759mm / 29,9 in	448mm / 17,6 in	292mm / 11,5 in	552mm / 21,7 in	558mm / 22,0 in	Ø76mm / 3,1 in	Ø102mm / 4,1 in

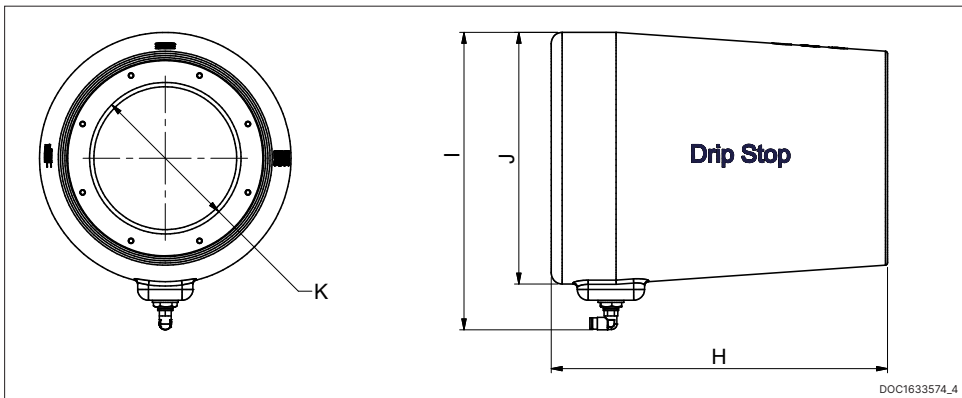

Model	H	I	J	K
Drip Stop DN80	275 mm / 10,8 in	257 mm / 10,1 in	216 mm / 8,5 in	1071 mm / 4,2 in
Drip Stop DN100	310 mm / 12,2 in	275 mm / 10,8 in	232 mm / 9,1 in	1317 mm / 5,2 in

2.5 Function of connections

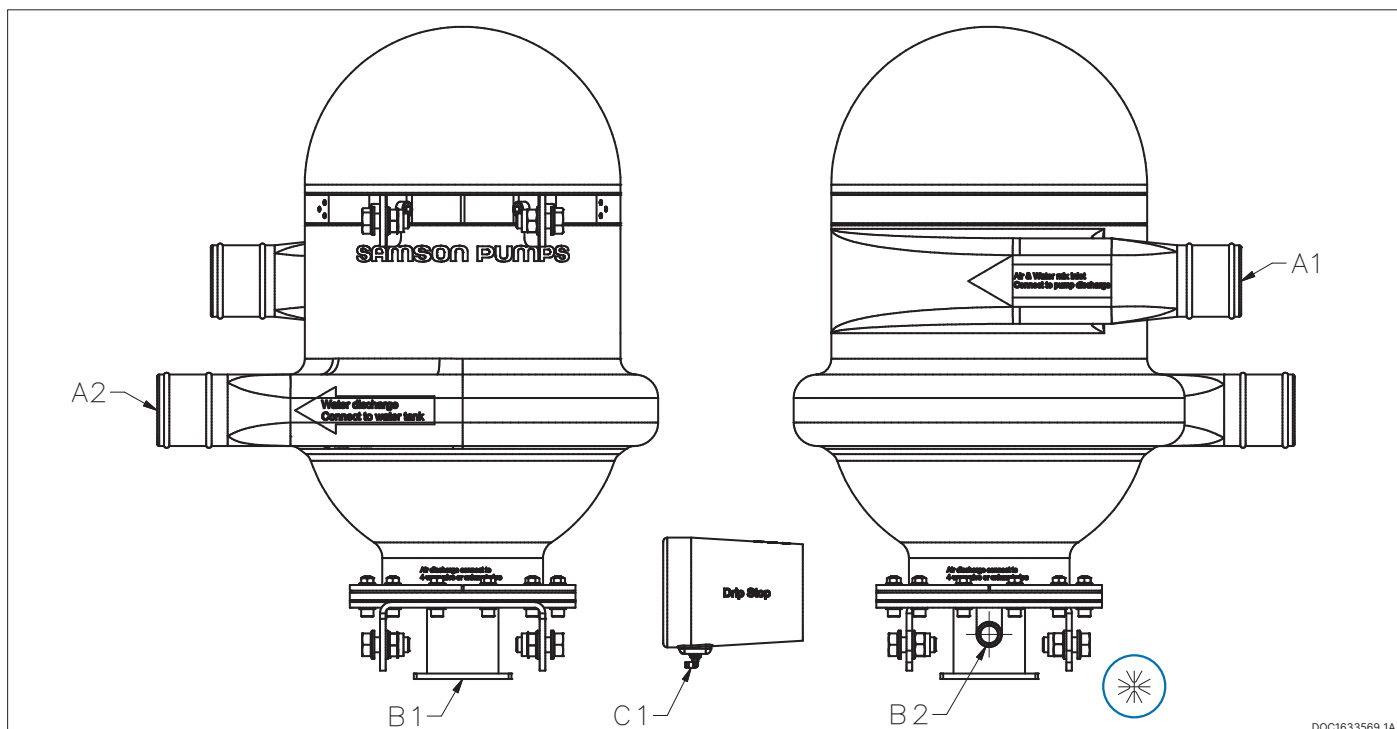

DOC1633569_1A

ID	Name	Function & how to connect	Water Separator DN80	Water Separator DN100
A1	Air & water mix inlet	Connect A1 to the discharge side of the pump.	3"	4"
A2	Water discharge	A2 will return the separated water and must be connected to water tank.	3"	3"
B1	Air discharge	B1 will return the separated air and must be connected to the 4way valve, or final exhaust piping.	DN80	DN100
B2	Drain 	B2 is a winterization drain hole, designed to drain away water-remains by gravity, after the vehicle stops operating. B2 can be connected to the pressure side of the liquid ring vacuum pump, where it will drain in between operations, automatically. See pump manual for further instructions.	G1/2"	G1/2"
C1	Drain from drip stop	Drains the drip stop for water accumulation. To be connected to suction side of the pump.	Ø8 hose	Ø8 hose



B1 connected to a 4way valve. In discharge position, the 4way valve will enable emptying of the vehicle slurry tank by connecting the pump discharge side.

2.6 Performance

The water separator is designed to separate water and air, from a liquid ring vacuum pump exhaust. This separation will not be 100%, but only partially. A minor part of the liquid exhaust will evaporate into the atmosphere and drops of liquid from the exhaust will occur as well.

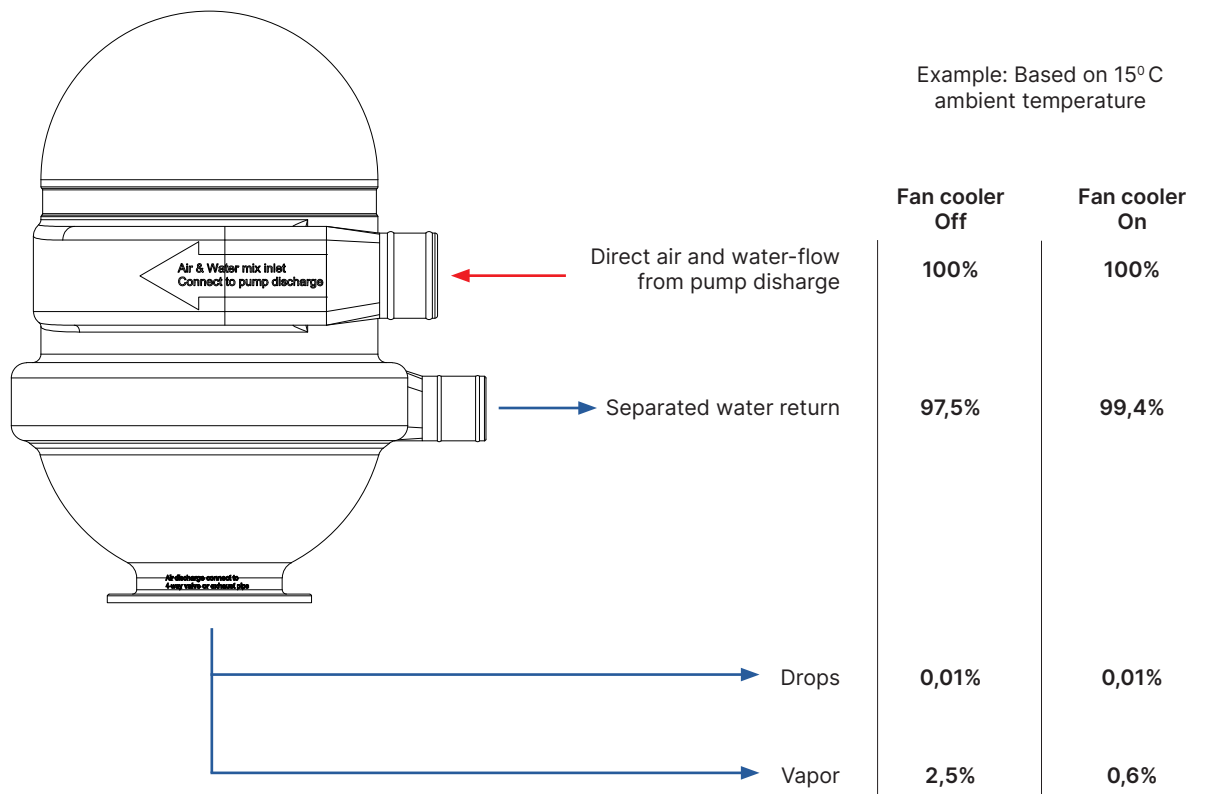

2.7 Right sizing

Vehicle suction hose	Recommended vacuum pump	4way valve	Recommended water separator
	Suction hose 2"	Truck Master 2	Water Separator DN80
	Suction hose 3"	Truck Master 3	
	Suction hose 4"	Truck Master 4	Water Separator DN100
	Suction hose 5"	Truck Master 5	
	Suction hose 6"	Truck Master 6	4way valve DN125

3 Design of a system

3.1 Mounting



A failure to meet these specifications may result in damage to the water separator

The water separator must be placed in a safe position on the vehicle, without risk of collision with branches, wires or other objects that may come in its way.

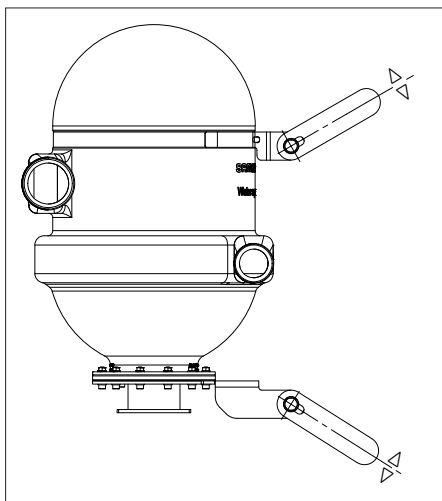

A: All four fittings are adjustable in individual angles.

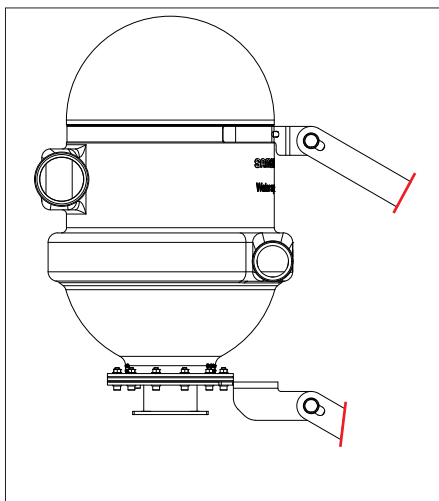

B: Modification to the specific project.

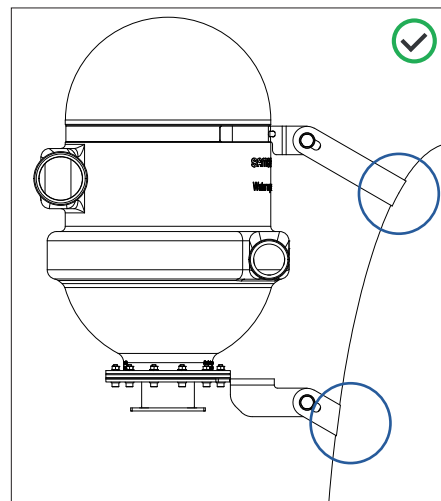

C: Ensure a safe mounting by welding the four fittings to the main structure of the vehicle.

3.2 Connection to internal pipe system



A failure to meet these specifications may result in damage to the water separator

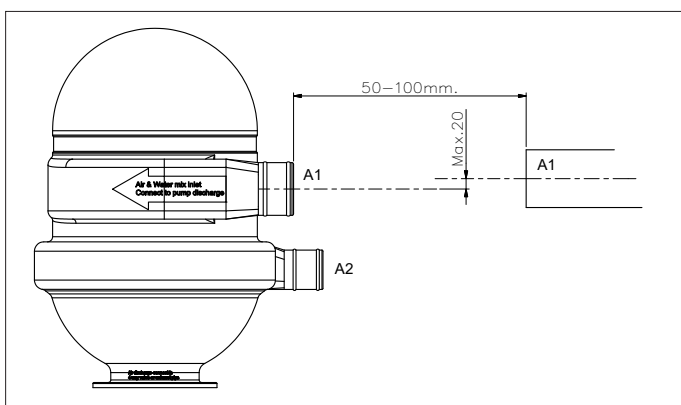

Its important that connection A1 and A2 is connected to a solid steel pipe.

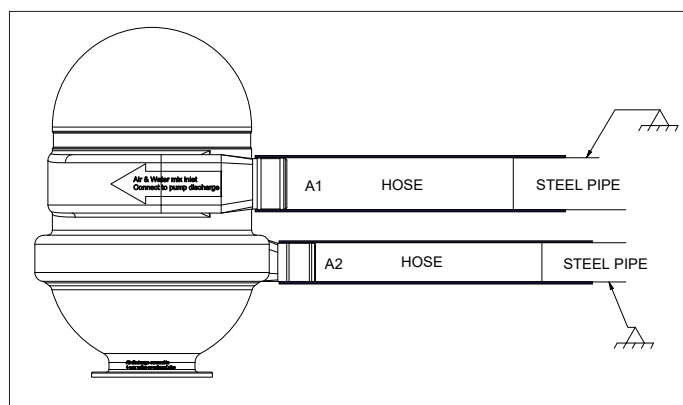

Connect A1 and A2 to the steel pipes by using a plastic hose sleeve.

3.3 Placing on the vehicle

The water separator must be placed in a safe position on the vehicle, without risk of collision with branches, wires or other objects that may come in its way.

It's also important to ensure a certain height to water separator: See illustration below:

The drip stop can be mounted horizontally, 45° inclined and vertically. It is important that Ø8 connection always is pointing downwards and the length of pipe from 4way valve to drip stop is min. 800 mm. See illustration below:

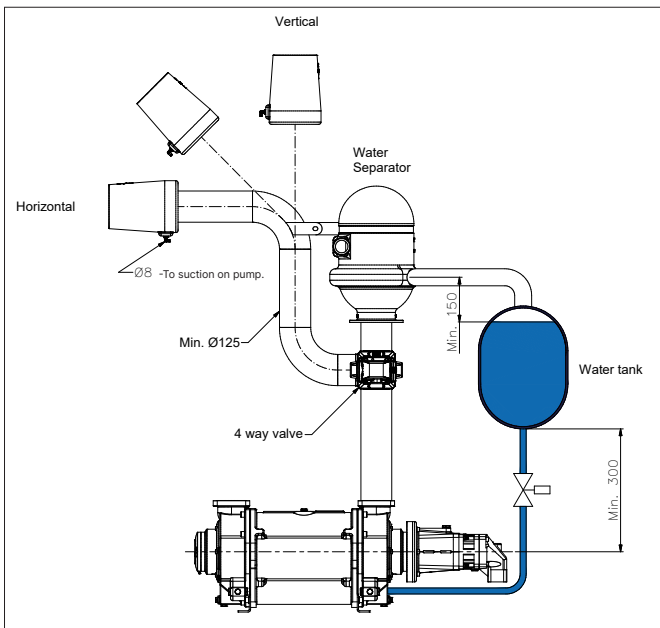

3.5 Pressure conditions in the water tank during pump operation

When the pump is operating in **vacuum mode**, the water tank will be at atmospheric pressure.

When the pump is operating in **pressure mode**, the water tank will be subjected to the same pressure level as the pump.

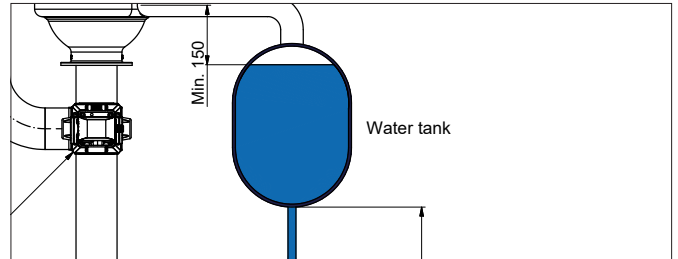

3.6 Drain procedures for water separator

The water separator must be drained from connection B2 to prevent accumulation of ice, and as a result of that, reduced performance. See pump manual for further instructions.

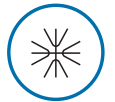

3.7 Water separator for Truck Master 6

To ensure the optimal operation of the system or installation, it is necessary to follow the instructions below:

For the system to function optimally, it is extremely important to do the following:

Install the water separators in such a way that both receive the same flow. The flow from the pump must be distributed equally between the two liquid separators, with 50% to one and 50% to the other.

If both do not receive the same flow, for example 70% to one and 30% to the other, proper water separation from the airflow cannot be guaranteed, resulting in reduced functionality.

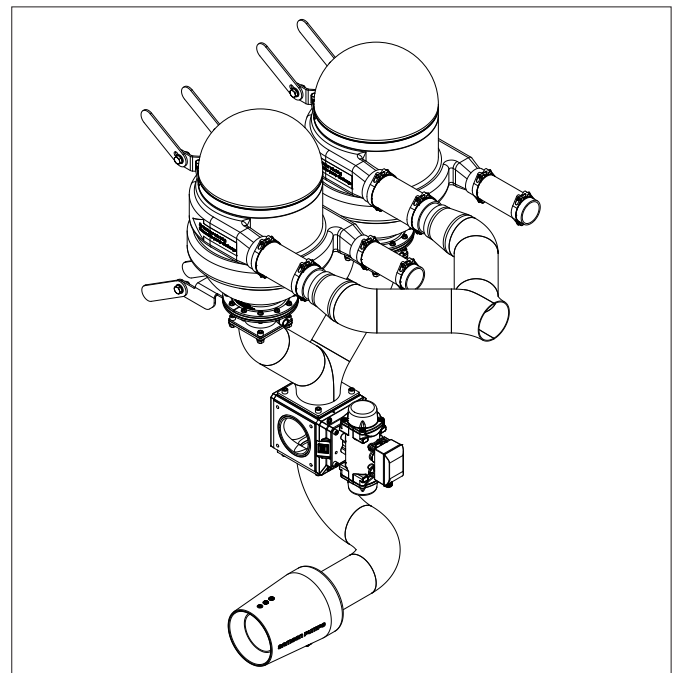

3.4 Welding the flange

Flange (Pos 4) and Pipe (Pos 13) to be welded in order to mount the drip stop on outlet.

Flange (Pos 4) is included in set and Pipe (Pos 13) is not included. It is the pipe on truck.

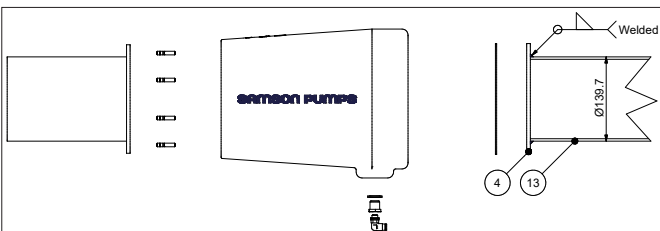

4 Installation and start-up

4.1 Installation



Installation requirements must be observed, otherwise there is a risk of damage

The water separator must be installed in such a way that is not twisted or exposed to a profile distortion. All connections must be tensionless.

Check that all connections are free and not clogged in any way.

4.2 Earth connection requirements



The pump must be connected to earth to prevent static electricity. Static electricity is a potential source of ignition
The earthing (grounding) connection for the water separator must have a full metal to metal contact
Applies exclusively to Ex versions



A failure to meet these specifications may result in damage to the water separator and a potential risk of explosion



Zone 0 & ZONE 1
This chapter relate to Ex Zone 0/1 & 1/1 approved water separators
(ATEX category 1 pumps)

The water separator must be protected from the creation of sparks in connection with static electricity, in accordance with the applicable regulations for use in the current categories. See illustration below for earth connection.

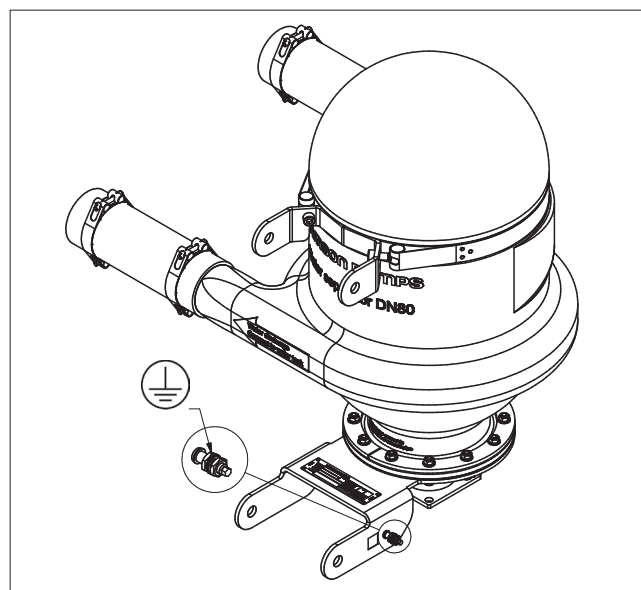

4.3 Installation on a tank tipper truck



Installation requirements must be observed, otherwise there is a risk of damage

The maximum tipping angle of water separator is 45°.

A1 and A2 hose connections must be pointing towards the tank.

Due to a higher liquid column pressure when the tank is tilted, it may be necessary to reduce the water flow to the pump.

See illustration below:

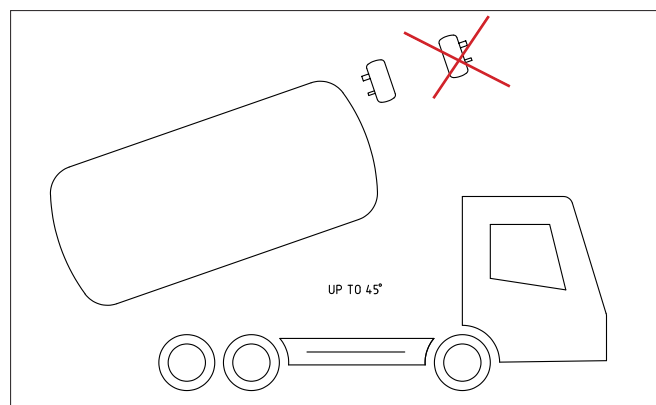

5 Service operation and maintenance and inspection intervals



- Check for foreign objects in the water separator

Section	Operation	Frequency
5.1	Winterization when below 0°C	When below 0°C
5.2	Inspection of 1/2" drain from water separator	Weekly
5.3	Visually inspect for leakage	Weekly

5.1 Winterization

The water separator is drained by connection B2.

5.2 Drain inspection

It is necessary to inspect the 1/2" drain from water separator to ensure that it is not clogged.

5.3 Visually Inspecting for leakage

The water separator and pipe system around the water separator must be inspected for leakage once a week. The inspection must be performed when the system is operating at idle. Any leaks must be repaired before operation may continue.

6 Spare parts and tools

To order spare parts, please visit the Samson Pumps Product center.

Buy



Product Center

7 Troubleshooting

Problem	Cause	Effect	Corrective measure
Water is coming out of the air discharge connection	<ul style="list-style-type: none"> • Water level in tank is too high • The connections are incorrect 	<ul style="list-style-type: none"> • Poor water separation 	<ul style="list-style-type: none"> • Check water level in tank • Check connections

8 Marking and identification

8.1 ID Plate location

The location of the identification plate (ID Plate) is to be found at the top of the steel bracket on Water Separator.

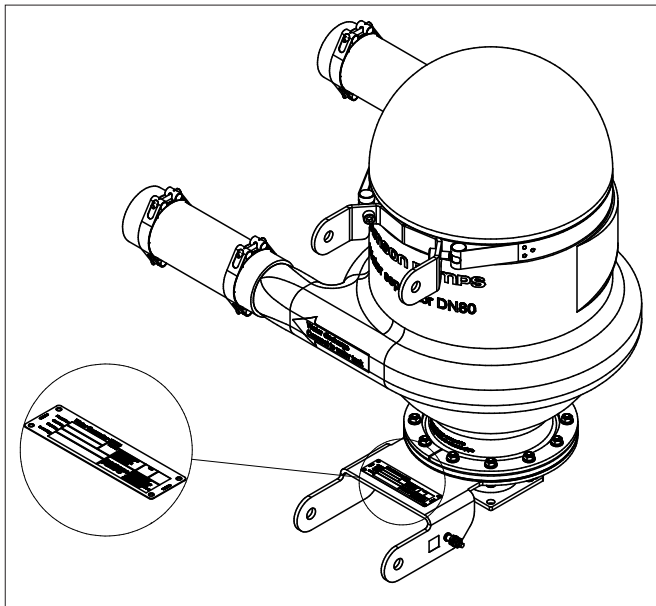

8.2 ID Plate

Recommended suction hose
 PED Category, Design and
 Operational Parameters
 CE conformity mark/Notified body No
 Ex Mark

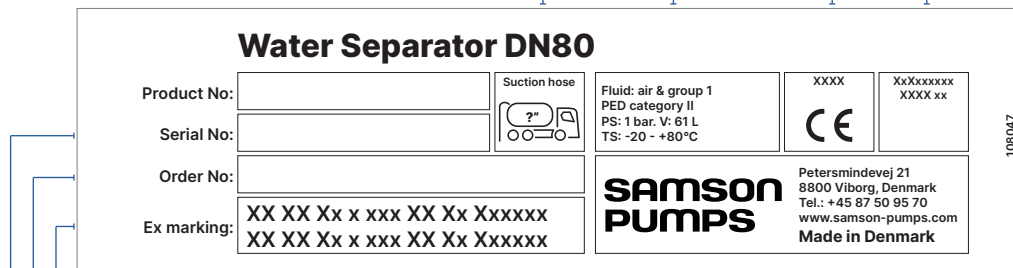

Classification
 Customer purchase reference
 Samson Pumps production reference