



INSTRUCTION MANUAL FOR
SAMSON LIQUID RING PUMPS, TYPES:
KM2200, KM2700



CONTENTS

1	Introduction	4
1.1	Declaration of conformity	4
1.2	Explanation of warning symbols.....	5
1.3	Marking and identification	5
1.4	Field of application	6
1.5	Disposal	6
2	Technical data.....	7
2.1	Dimensions	7
2.2	Specifications	8
2.3	Power consumption and output.....	9
2.3.1	Vacuum	9
2.3.2	Pressure.....	9
2.3.3	Correction factor.....	10
2.4	Handling and transport.....	10
2.5	Pump storage.....	11
2.6	Materials	12
3	Design of the systems	14
3.1	The pump's function.....	14
3.2	System layout example	15
3.3	Liquid separator	16
3.4	Cooling system.....	17
3.4.1	KM2200 - Vacuum.....	19
3.4.2	KM2200 - Pressure	20
3.4.3	KM2700 - Vacuum.....	21
3.4.4	KM2700 - Pressure	22
3.5	Pipe system.....	23
3.6	Service liquid requirements.....	23

4	Installation and start-up.....	24
4.1	Securing the pump	24
4.2	Connections to the pump	24
4.3	Connecting the service liquid	25
4.4	Transmission	25
4.5	Prior to start-up	26
4.6	Direction of rotation	26
5	Recommended service, maintenance and inspection intervals.....	27
5.1	Draining the liquid separator	27
5.2	Check grease cartridges	27
5.3	Lubrication of bearings.....	28
5.4	Inspection and cleaning of service liquid's supply pipe.....	28
6	Troubleshooting	29
7	Spare parts.....	30

1 INTRODUCTION

1.1 Declaration of conformity



Declaration of Conformity

Annex IIA

Samson Pumps A / S

Petersmindevej 21
DK-8800 Viborg

Hereby declares that the following products:

**Liquid ring pump
KM2200, KM2700**

Conforms to the directive:

Machinery Directive 2006/42/EC

I hereby declare, that the liquid ring pumps are in conformity with the following harmonized standards:

DS/EN ISO 12100:2011	Safety of machinery - General principles for design - Risk assessment and risk reduction
DS/EN 1012-2 + A1:2009	Compressors and Pumps - Safety requirements - Part 2: Vacuum pumps

The standards above only apply to the extent that it is relevant for the purpose of the pump. The product must not be used before the complete system, which it must be incorporated in, has been conformity assessed and found to comply with all relevant health and safety requirements of 2006/42/EC and other relevant directives. The product must be included in the overall risk assessment.

Viborg, 09.03.2017

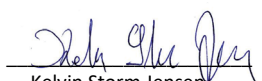
Kelvin Storm Jensen
R&D Manager
Samson Pumps A/S

DOC4008B

Email | info@samson-pumps.com | Samson Pumps A/S | Petersmindevej 21
Web | www.samson-pumps.com | Phone | +45 87 50 95 70 | DK-8800 Viborg

1.2 Explanation of warning symbols

Important technical and safety instructions is showed by symbols. If instructions not performed correctly, may lead to personnel injury or incorrect function of the pump.



To be used with all safety instructions that must be followed. A failure to follow the instructions may result in injury and/or incorrect machine operation.

1.3 Marking and identification

The pump is equipped with an identification plate that is shown below.

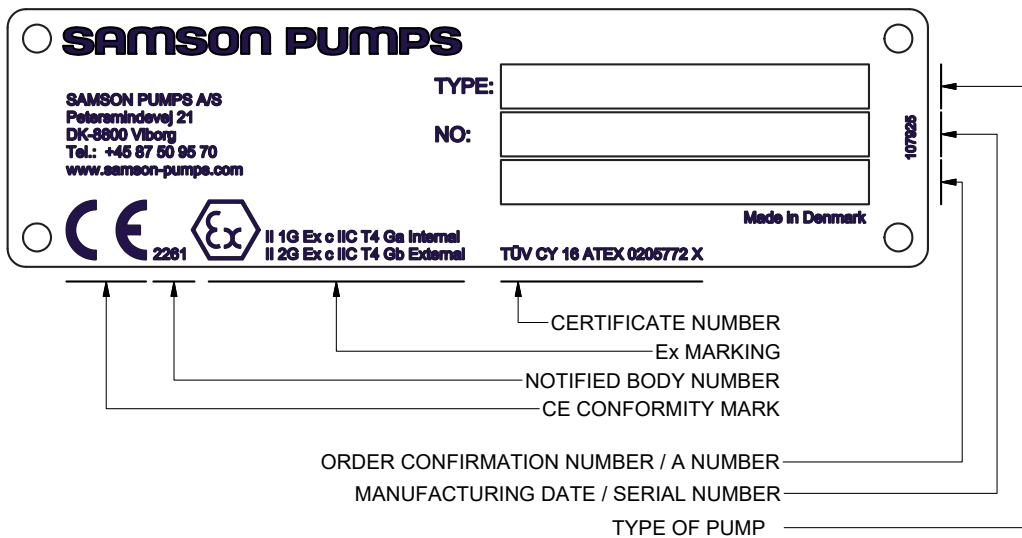

Configuration example:

KM 2200 R 0 S S B 0 0 A X1

- Type: ←
- Model: ←
- Rotation: ←
- Rotor type: ←
- Pump housing: ←
- Shell: ←
- Flow plates: ←
- Mechanical shaft seals: ←
- Gaskets: ←
- Colour: ←
- Documentation: ←

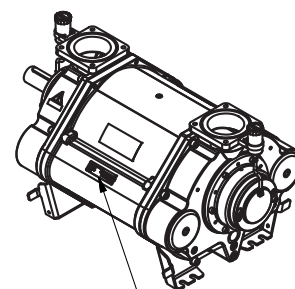

Location of ID plate

DOC107925_8

1.4 Field of application



Inlet of foreign objects can damage the pump.



The pump is designed exclusively to pump gases, including atmospheric air.



WARNING!
Do not operate the pump so that cavitation can occur! For further information see instruction manual for the Samson Pumps vacuum limiter.

It must be ensured that the inlet gas cannot react with the service liquid and create aggressive bonds that break down the pump's components.

For other operating data, see specifications.

- The pump may only be used with media that are not aggressive to the pump's materials. See section 2.6 for components and appertaining materials.

1.5 Disposal

Samson's liquid ring pump is manufactured so that most of the device can be reused/recycled.

Samson Pumps thus offer users of the company's pumps the option of returning used pumps to be restored or scrapped.

For those who do not wish to take up the factory on this offer, the pump must be taken apart and sorted into its separate components. See section 2.6 for the material of which the pump is made.

These components must be disposed of in accordance with national regulations.

2 TECHNICAL DATA

2.1 Dimensions

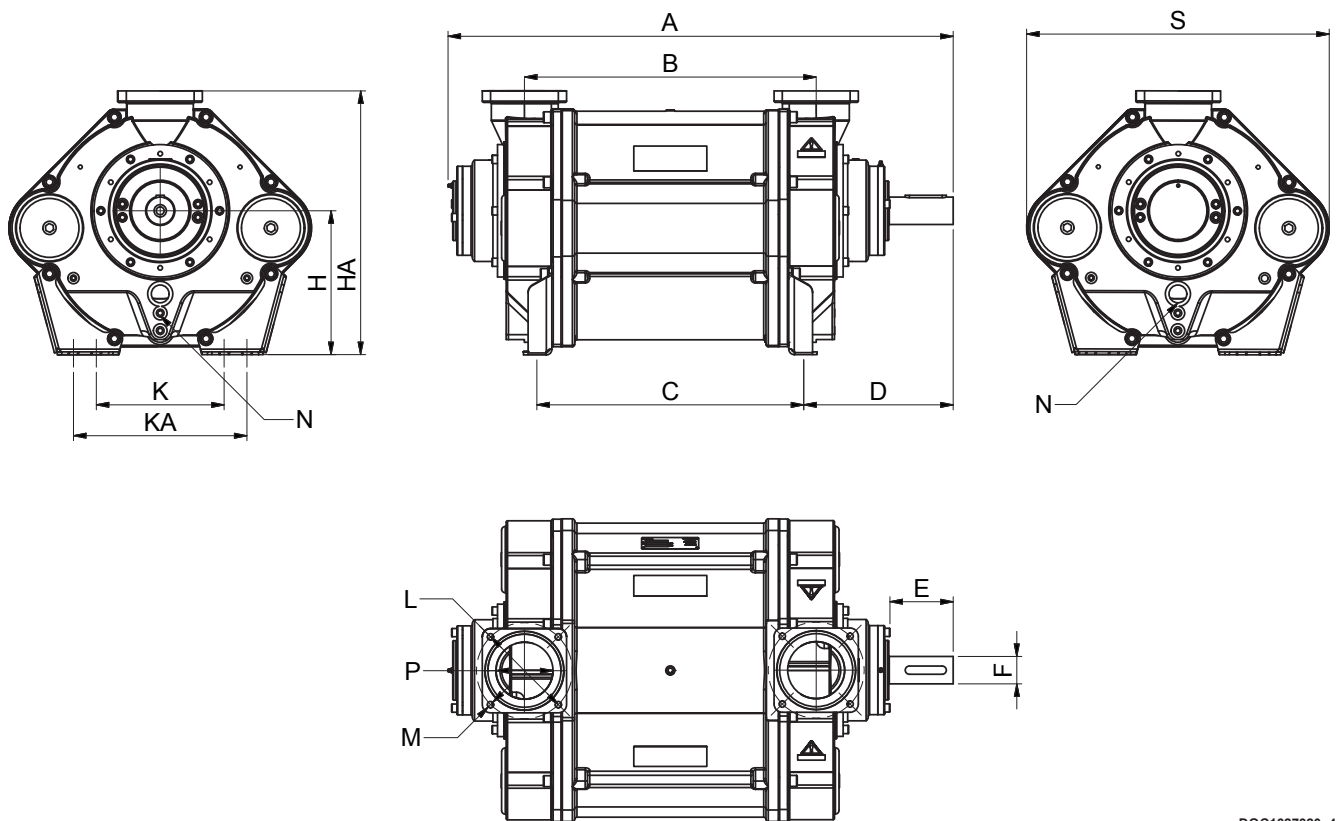

DOC1627320_4

Dimensions [mm]																	
Pump type	A	B	C	D	E	F	H	HA	HB	K	KA	L	M	N	P	S	Weight [kg]
KM2200	1112	640	605	318	140	Ø60 / k6	315	580	635	280	380	Ø210	M16	1¼"	Ø125	665	465
KM2700	1242	775	740	318	140	Ø60 / k6	315	580	635	280	380	Ø210	M16	1¼"	Ø125	665	540

2.2 Specifications



A failure to meet these specifications may result in damage to the pump.

Description		Minimum	Maximum
Ambient temperature, operation		-20°C	55°C
Ambient temperature, storage		-20°C	55°C
Humidity		-	80%
Intake temperature, suction side		-	120°C
Intake temperature, service liquid		-	90°C
Service liquid pipe connection, dimension		1¼"	-
Service liquid pipe connection, length		-	6 m
Noise level		-	80 dB
Maximum radial load on drive shaft	KM2200	-	4950 N
	KM2700	-	5350 N
Revolutions		800 rpm	1480 rpm
Pressure		150 mbara	2 barg
Service liquid flow		5 litres/minute, self-regulating*	
Lubricating grease	Type of grease	SKF LGWA2	
	Automatic lubrication	SKF LAGD 125/WA2	

* -It is recommended to install liquid separator to ensure the pump is supplied with as much water as needed.

2.3 Power consumption and output

2.3.1 Vacuum

KM2200

	Pressure	[mbara]	150	200	300	400	500	600	700	800
800 [rpm]	Flow	[m³/h]	385	520	790	940	982	992	999	992
	Consumption	[kW]	33.3	34	34	34.1	34	33.9	33.2	32.5
1180 [rpm]	Flow	[m³/h]	1420	1510	1610	1640	1640	1620	1604	1595
	Consumption	[kW]	57.8	59	61	61	59.5	57.5	55	52.5
1480 [rpm]	Flow	[m³/h]	1925	2000	2105	2150	2145	2120	2101	2080
	Consumption	[kW]	89.8	91	92.8	92.8	90.5	90	88.5	86

KM2700

800 [rpm]	Flow	[m³/h]	720	900	1220	1400	1435	1410	1390	1340
	Consumption	[kW]	28.3	29.5	32	34	35	34	31.9	29
1180 [rpm]	Flow	[m³/h]	1215	1490	1900	2180	2285	2280	2220	2140
	Consumption	[kW]	52.5	56	62	66.8	68	66.5	64	61.5
1480 [rpm]	Flow	[m³/h]	1800	2100	2600	2900	2990	3000	2970	2935
	Consumption	[kW]	84.5	88	95	99	100	100	100	100

2.3.2 Pressure

KM2200

	Pressure	[barg]	0.3	0.4	0.5	0.6	0.7	0.8	0.9	1	1.5	2
800 [rpm]	Flow	[m³/h]	810	800	780	710	690	620	590	520	200	-
	Consumption	[kW]	34	36	37	38	40	42	43	45	55	-
1180 [rpm]	Flow	[m³/h]	1510	1505	1490	1480	1420	1400	1380	1320	1050	600
	Consumption	[kW]	71	72	74	75.5	77	78	80	82	89	96
1480 [rpm]	Flow	[m³/h]	2060	2020	2000	1990	1950	1910	1890	1840	1600	1180
	Consumption	[kW]	97.5	100	102	105	107	110	112	115	128	142

KM2700

800 [rpm]	Flow	[m³/h]	1180	1100	1020	990	910	850	790	700	300	-
	Consumption	[kW]	53	54	56	58	60	62	64	66	77	-
1180 [rpm]	Flow	[m³/h]	2210	2190	2160	2120	2100	2080	2020	1995	1750	1500
	Consumption	[kW]	70	72	74.5	76	78	80	82.5	84.5	93	107
1480 [rpm]	Flow	[m³/h]	2720	2700	2685	2645	2610	2590	2550	2505	2250	2050
	Consumption	[kW]	108	110	113	115	117.5	120	122.5	125	137	149

The data is based on the following parameters:

- Air temperature 20°C
- Service liquid temperature 15°C
- Test performed with dry air and 1,013 mbar absolute.
- Tolerance ±10%

2.3.3 Correction factor

When the temperature of the service liquid exceeds 15°C, the pump's capacity will be affected with respect to the specified values.

To determine the output at a higher temperature, the correction factor can be used.

Capacity at service liquid temperature higher than 15°C :

$$Q_{>15} = Q_{15} \times K_1$$

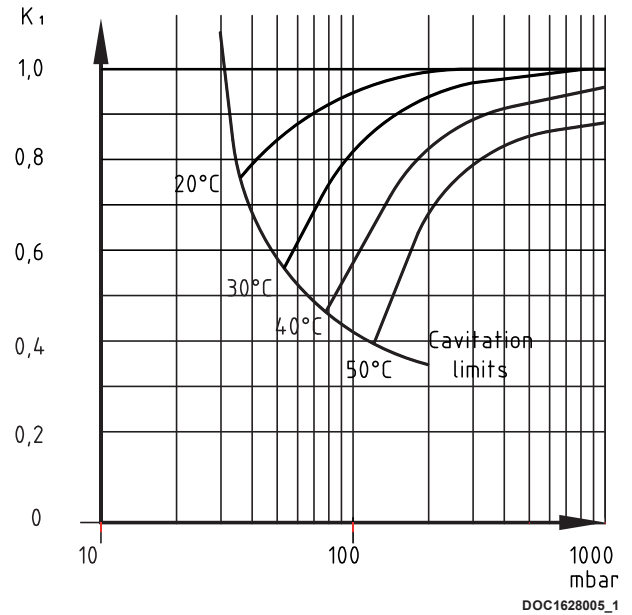

2.4 Handling and transport



The pump may not be used if it is damaged or the identification plate is missing!

The pump must be transported in such way that is not exposed to vibrations and impacts that can overload the bearings.

The pump must be inspected for damages upon delivery. If the pump is damaged, it may not be used and the damage must be reported to the dealer.

Ensure that the pump's identification plate is intact and that the marking of the pump corresponds to its use.

The pump may only be handled using approved lifting eyes, in accordance with nationally applicable regulations and only in a vertical motion.

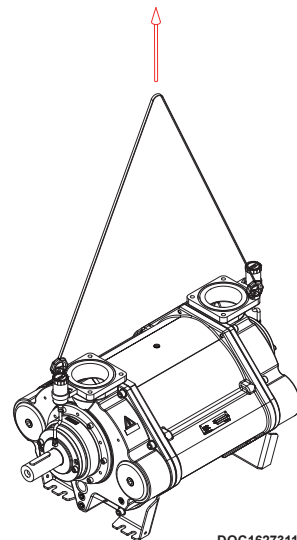

The pump can be transported in the following ways:

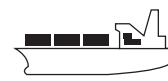

DOC11093A

2.5 Pump storage



A failure to comply with the requirements for storing the pump may result in internal damage to the device.



If the temperature is below freezing point of the service liquid, it may damage the pump. Under these conditions the pump must be drained completely.



All plugs and protective covers must be fitted during storage.

The pump's service liquid is drained on delivery, and the pump can be immediately stored in accordance with the technical specifications.

After operation, the pump can be stored for 30 days without further action.

If the pump remains out of operation for a longer period of time after use, its service liquid must be drained, and the liquid supply to the pump must be shut off.

When emptying the pump, it is important that all compartments inside the pump are emptied.

The pump can be fitted with valves in the draining connections. See below.

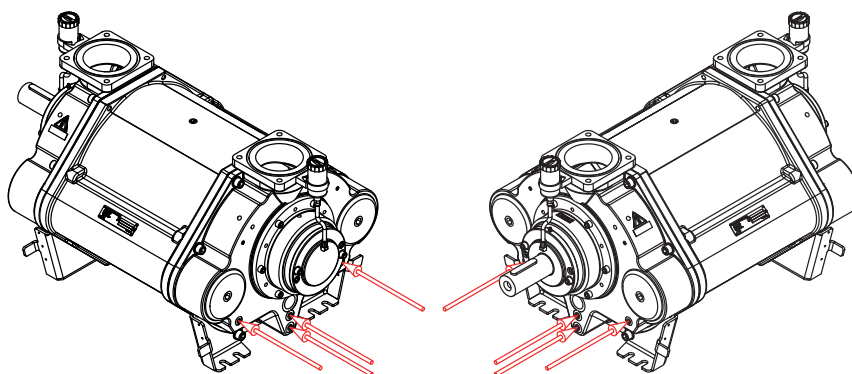

DOC1627313_1A

2.6 Materials

Term	Pos.	Material	Description
Shaft nut	1	Steel	GB/T 8162-Q
Ball bearing	2	Chrome steel	W.Nr.1.3505
Bearing housing	3	Cast iron	EN-GJL-250; EN1561
Rear cap	4	Stainless steel	AISI 304
Retainer	5	Stainless steel	AISI 316
O-ring	6	Rubber	NBR 70; DIN 3771
Mechanical shaft seal	7	NBR / AISI / Carbon	-
Stop ring	8	Stainless steel	W.Nr.1.4404
O-ring	9	Rubber	NBR 70; DIN 3771
Pump housing	10	Cast iron	EN-GJL-250; EN1561
Gasket	11	Rubber	NBR
Paper gasket	12	Paper	Oakenstrong
Paper gasket	13	Paper	Oakenstrong
Identification plate	14	Stainless steel	AISI 316
Rotor	15	Steel	W.Nr.1.4418 / 1.4404
Bearing cover	16	Cast iron	EN-GJL-250; EN1561
Lock washer	17	Steel	DC01 SS-EN 10130: 1995
Radial shaft seal	18	Rubber	Type CB NBR; DIN 3760A
Foot bracket	19	Steel	S235
Fitting**	20	Brass	-
Push-in nipple**	21	Brass	-
Push-in nipple**	22	Brass	-
Clamp for automatic lubricator**	23	Polyamide	PA6
Automatic lubricator LAGD 125/WA2**	24	Polyamide	PA6
Flexible tube for automatic lubricator**	25	Polyamide	PA6
O-ring	26	Rubber	NBR 70; DIN 3771
Flow plate*	27	Cast iron	EN-GJL-250; EN1561
		Bronze	GC-CU Sn10 DIN 1705
Shell	28	Cast iron	EN-GJL-250; EN1561

*-See section 1.3 for configuration of pump.

**-Optional. Not equipped as standard.

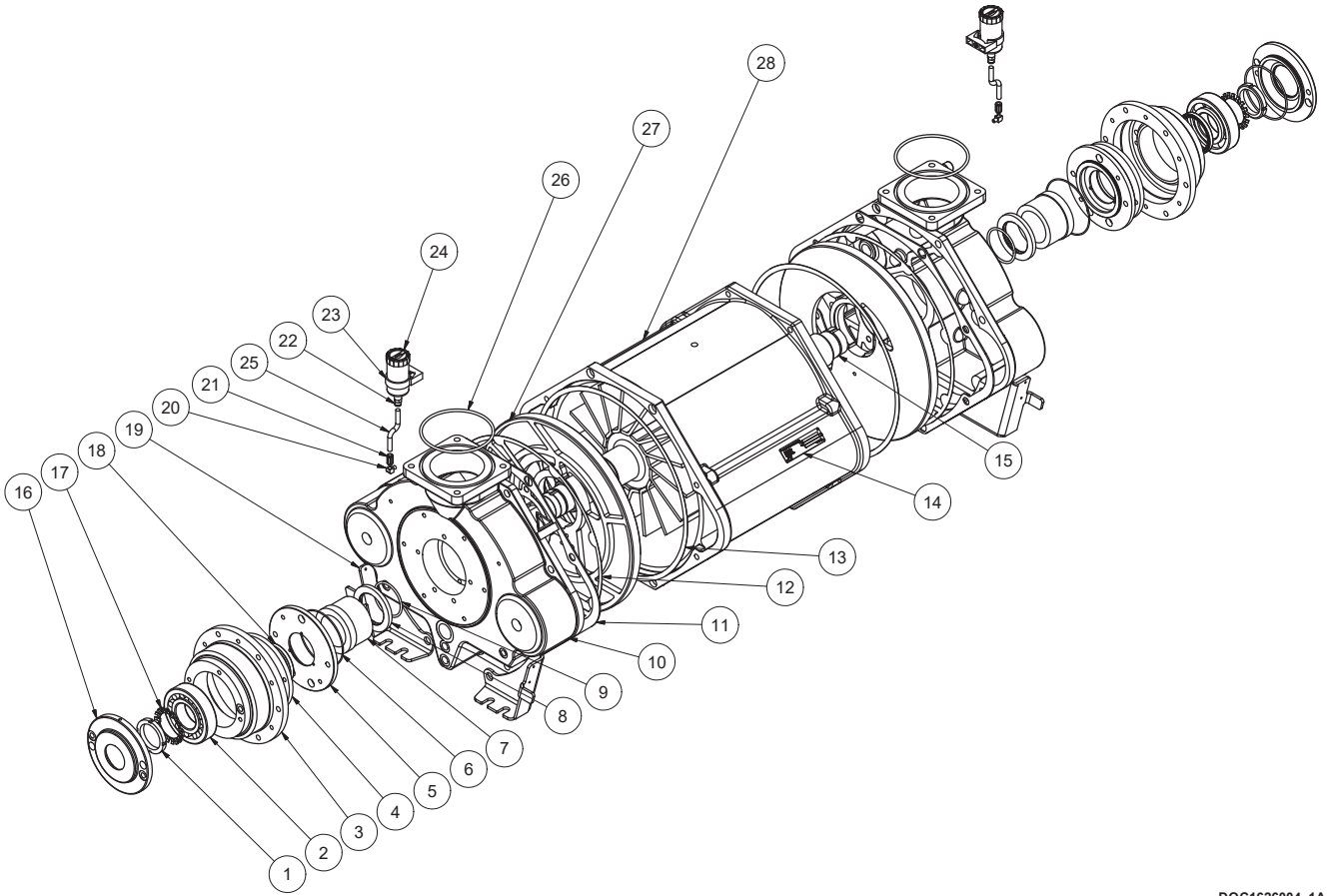

DOC1626004_1A

3.2 System layout example



- The product does not get sucked into the system, by installing of suitable level transmitter.
- The maximum working pressure does not exceed specifications, by installing a safety valve.

The liquid ring pump can be integrated in a system which takes advantage of both sides of the pump, vacuum and pressure. The example on illustrates the pump installed with a 4-way valve and a product tank. The 4-way valve, depending on position, will fill the tank by vacuum or empty the tank by pressure.

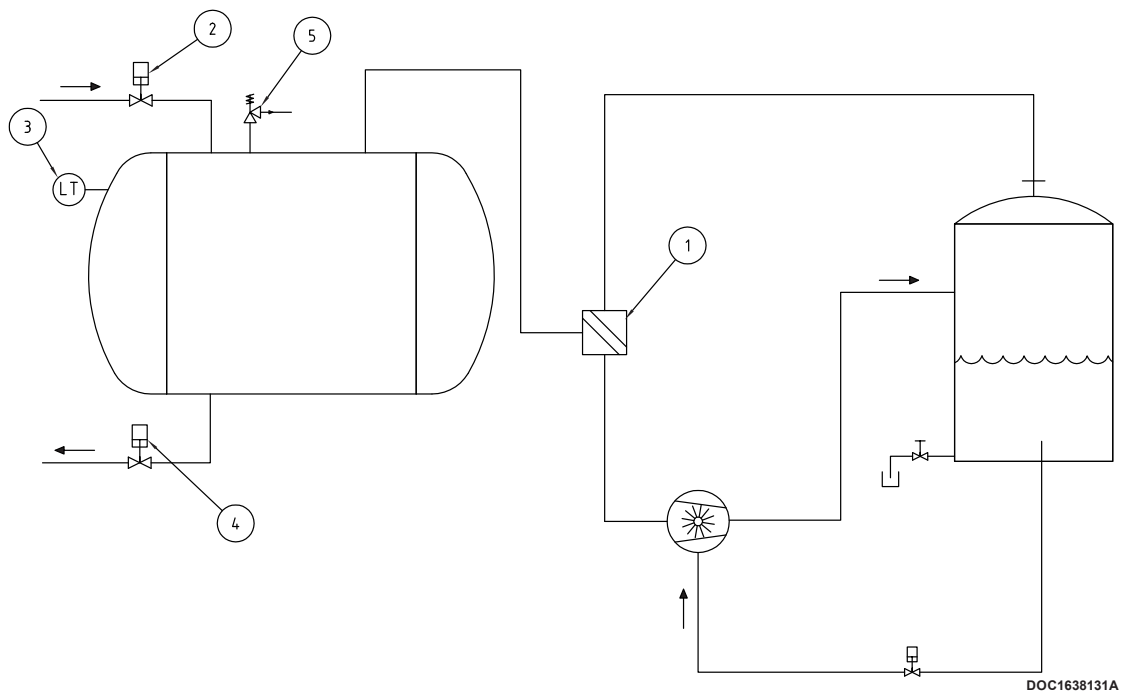

Pos.	Description
1	4-way valve
2	Suction valve
3	Level transmitter
4	Discharge valve
5	Safety valve

3.3 Liquid separator



Liquid separator is mounted in such way that the minimum level of service liquid is minimum 0,5 m above the pump's shaft.

To prevent calcium deposits, use a liquid separator or take necessary measures to prevent calcium in the service liquid.

The liquid separator is located in immediate proximity to the pump, so that the length of the outlet pipe from the pump is minimised.

Due to potential pressure loss, the length may not exceed 2 metres. The level of liquid in the liquid separator is recommended to be kept at 1-1.5 metres above the pump's shaft. This ensures the correct influx pressure and the correct flow of service liquid.

The liquid supply between the liquid separator and pump must be implemented with a permanent pipe connection with a dimension and length specified in specifications.

It may be advantageous to fit the liquid separator with a float valve, which automatically supplies liquid and maintains a constant level.

The liquid separator can be fitted with a drain valve at the lowest place in the tank. The valve can be operated when the separator needs to be drained to remove contaminants.

3.4 Cooling system

The compression in the pump generates heat, which will cause the temperature of the service liquid to rise. This means that it will often be necessary to cool the liquid. This can be done using an air cooler or heat exchanger. For short-term operation with intermittent breaks, natural cooling may be sufficient.

Depending on the temperature, the suctioned gas may be sufficient for cooling purposes, though it may also lead to an increased need for cooling.

The necessary cooling requirement can be found in chapters 3.4.1 to 3.4.4

Delta T (Δt) is the temperature difference between the suctioned gas (T_1) and the maximum acceptable service liquid temperature (T_2). See below.

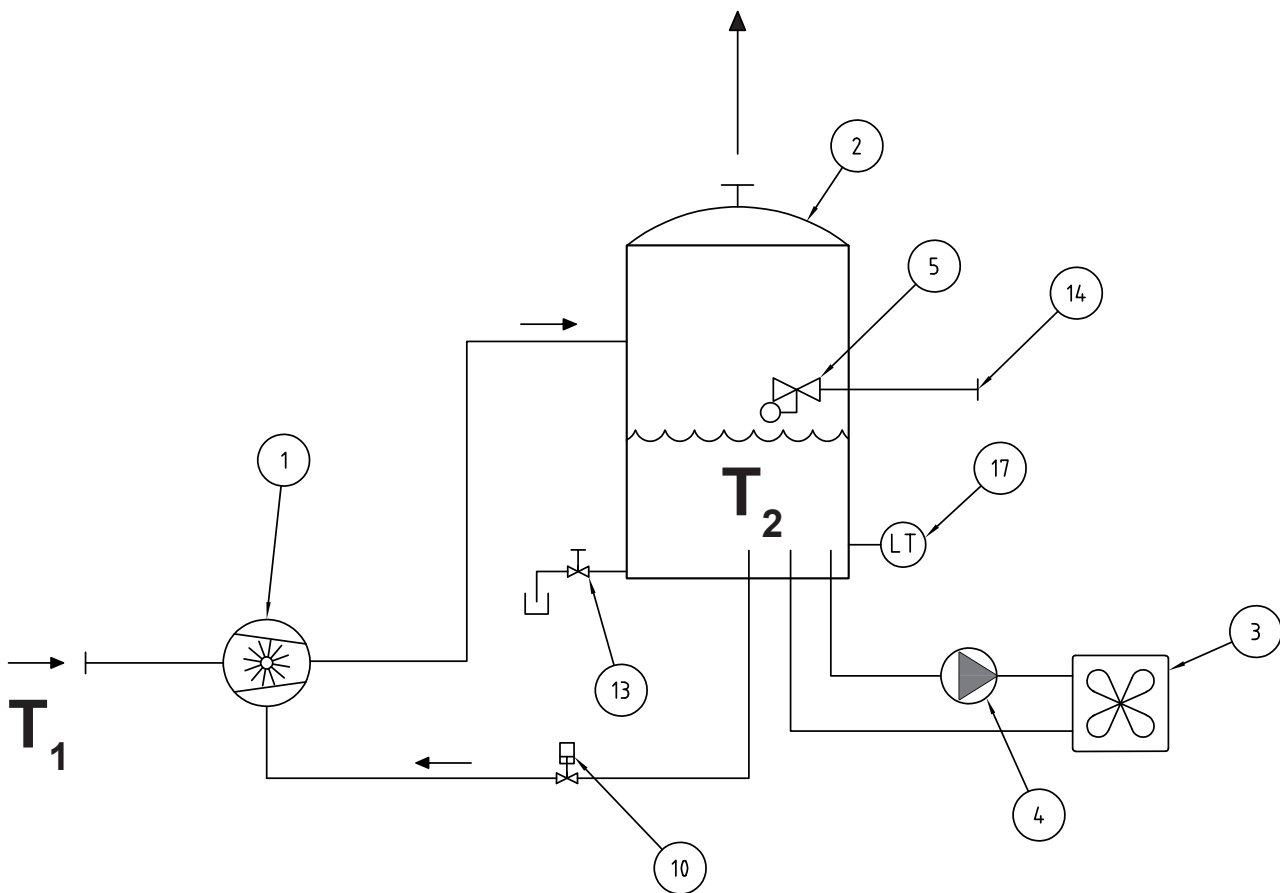

1638149

Pos.	Description
1	Vacuum pump
2	Liquid separator
3	Cooler
4	Circulation pump
5	Float valve
10	Stop valve
13	Drain valve
14	Service liquid connection
17	Level transmitter

Example 1: The intake temperature is 5°C, and the desired maximum service liquid temperature is 45°C.

$$\Delta t = 5 - 45 = -40^\circ\text{C}.$$

The cooling requirement at a pressure of 550 mbara will be 3 kW. See below.

Example 2: The intake temperature is 60°C, and the desired maximum service liquid temperature is 30°C.

$$\Delta t = 60 - 30 = 30^\circ\text{C}.$$

The cooling requirement at a pressure of 700 mbara will be 4.8 kW. See below.

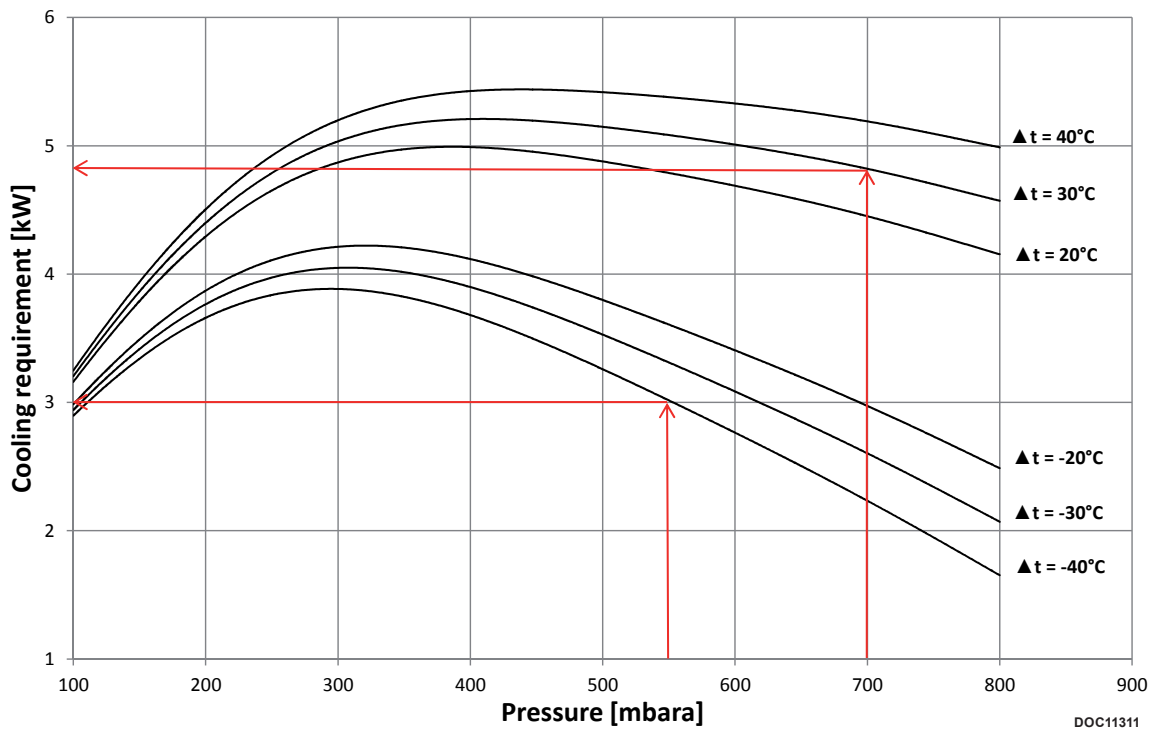

3.4.1 KM2200 - Vacuum

KM2200 - 800 rpm - Vacuum

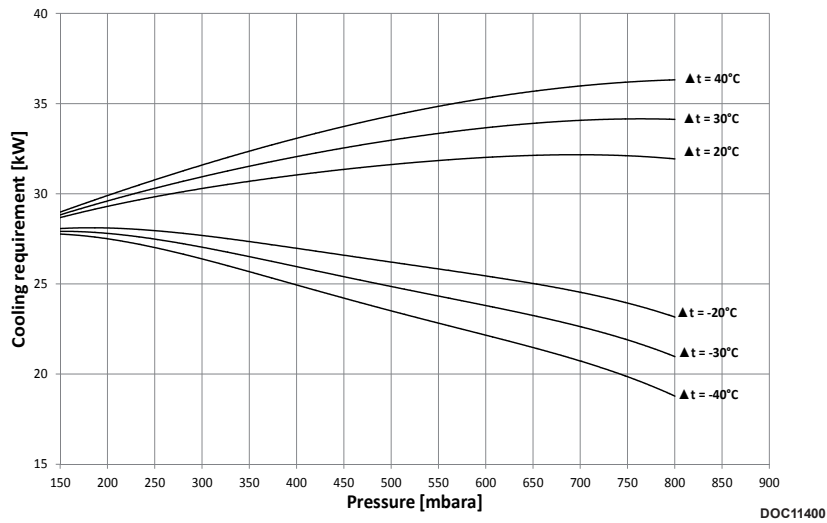

DOC11400

KM2200 - 1180 rpm - Vacuum

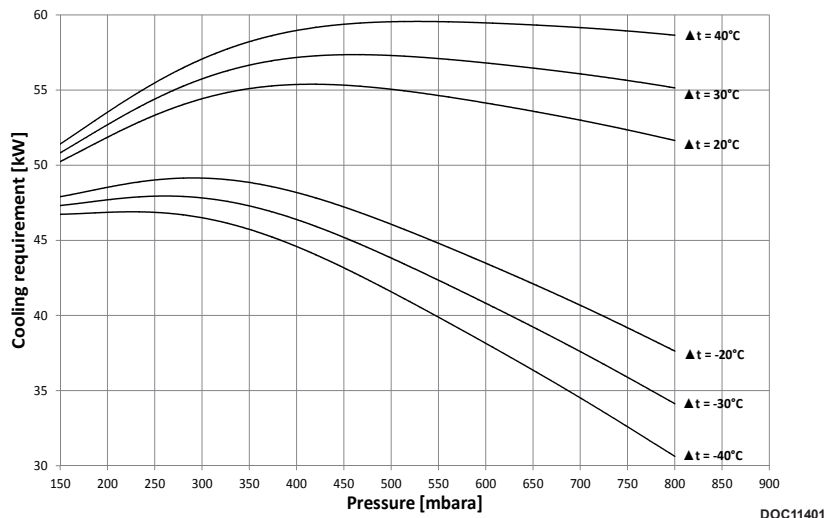

DOC11401

KM2200 - 1480 rpm - Vacuum

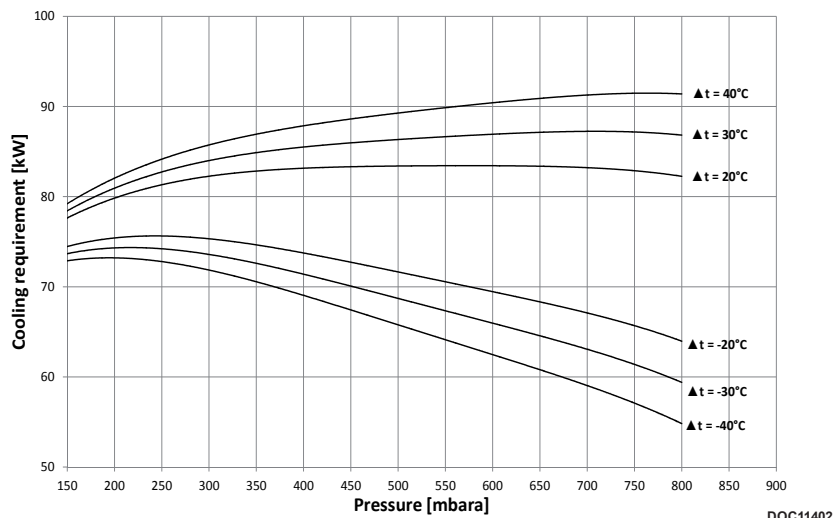

DOC11402

3.4.2 KM2200 - Pressure

KM2200 - 800 rpm - Pressure

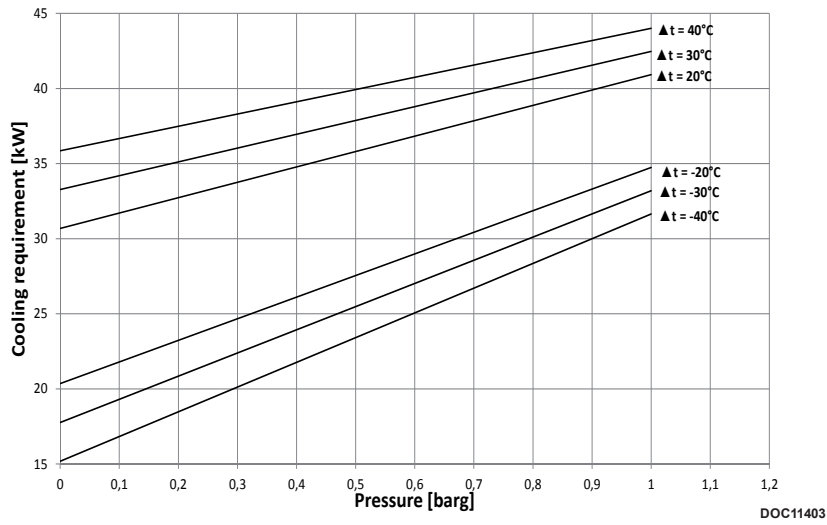

KM2200 - 1180 rpm - Pressure

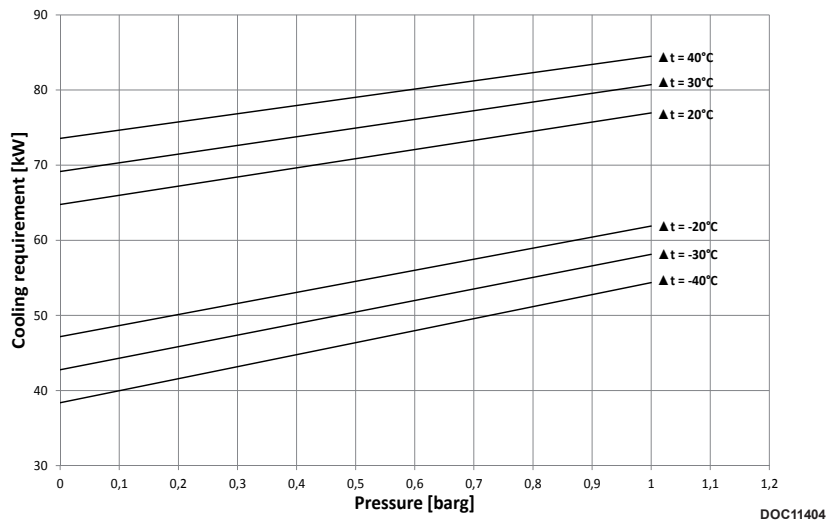

KM2200 - 1480 rpm - Pressure

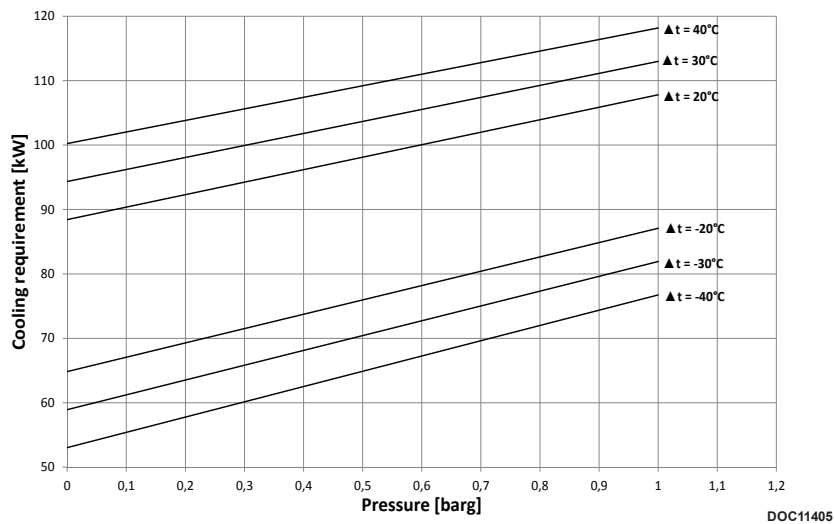

3.4.3 KM2700 - Vacuum

KM2700 - 800 rpm - Vacuum

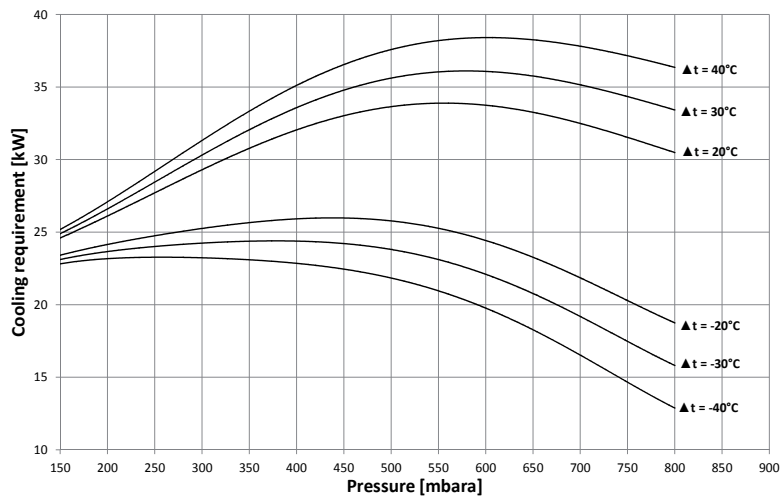

DOC11406

KM2700 - 1180 rpm - Vacuum

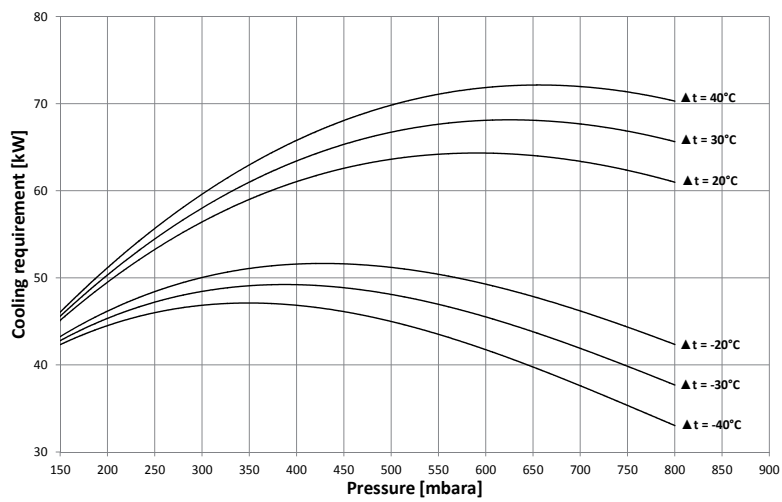

DOC11407

KM2700 - 1480 rpm - Vacuum

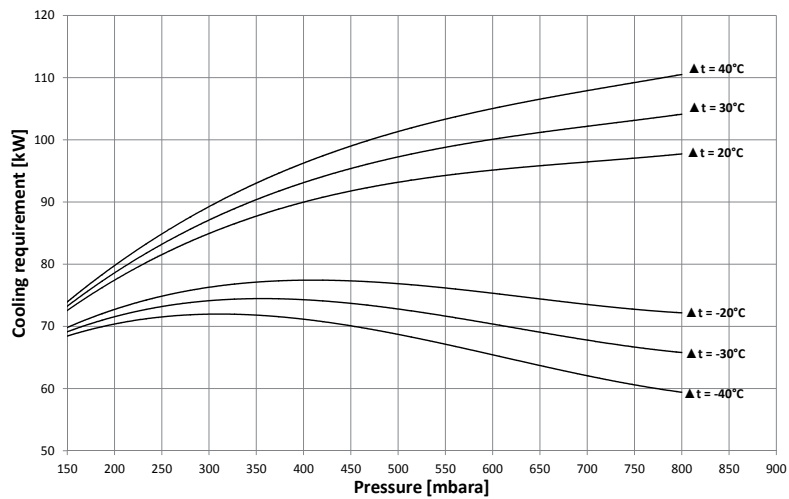

DOC11408

3.4.4 KM2700 - Pressure

KM2700 - 800 rpm - Pressure

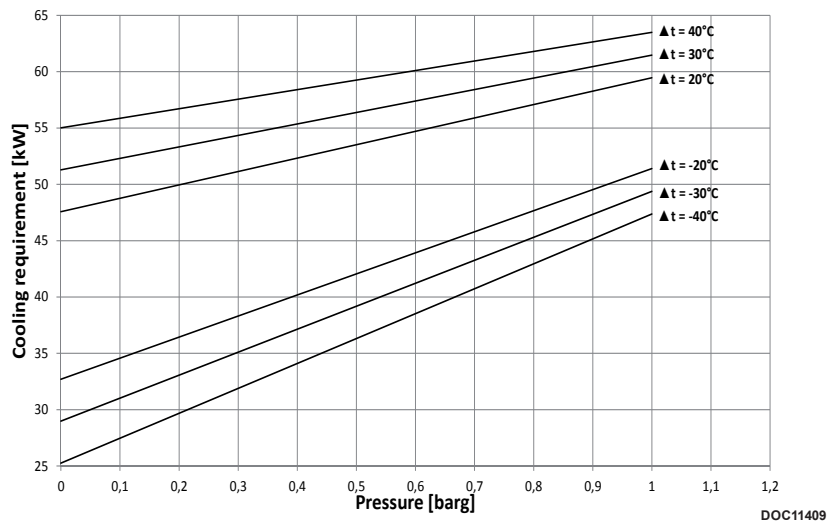

KM2700 - 1180 rpm - Pressure

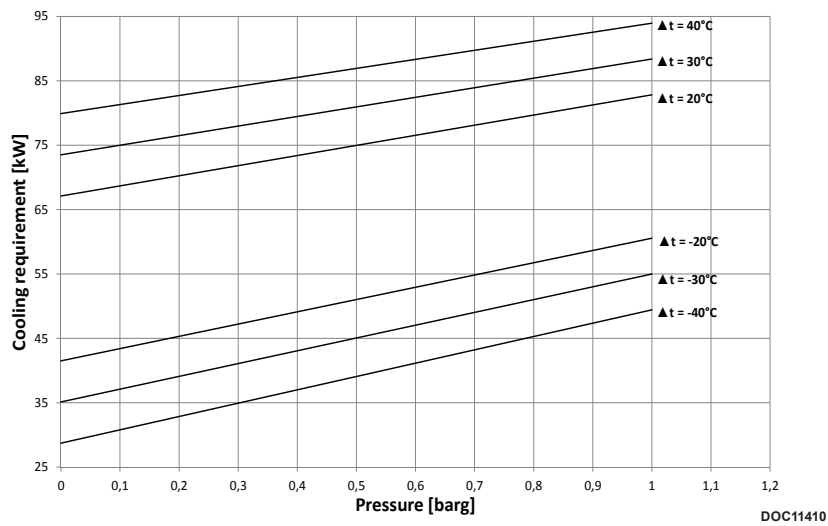

KM2700 - 1480 rpm - Pressure

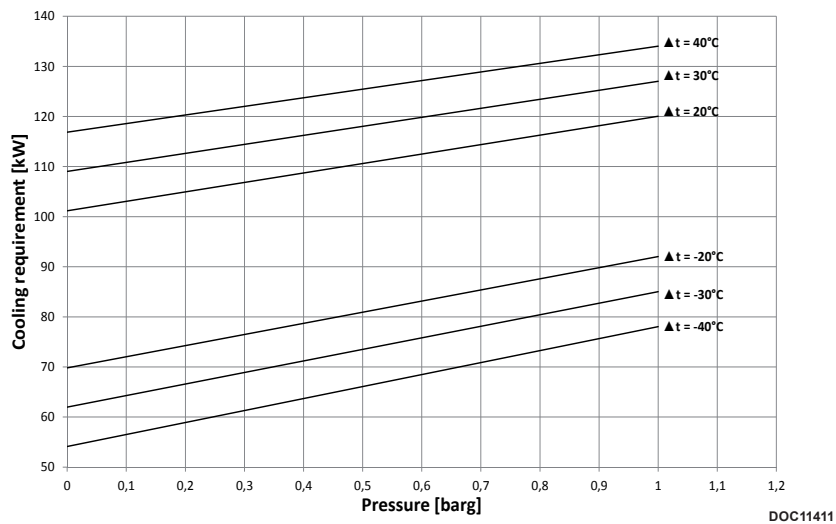

3.5 Pipe system

The pipes that are connected to the pump's suction and outlet sides must be at least the same dimension as the pump. The length of the pipe system affects the pump's capacity and should be calculated to account for pressure drop in longer pipe installations.

Depending on the operating pressure, longer pipe lengths may affect the pump's output. For pipe lengths greater than 20 metres, a pressure drop calculation should be made, and the pipe dimensions should be increased so that the pressure loss is held to an acceptable level.

The pipe system should be mounted so that the horizontal pipes have a min. of 1% decline back towards the liquid separator.

Table below can be used for reference values.

Connection	Length < 20 metres	Length 20-50 metres	Length 50-100 metres
Suction side	Min. DN 125	Min. DN 150	Min. DN 200
Outlet side	Min. DN 125	Min. DN 150	Min. DN 200

The outlet from the liquid separator should be led outside of the building, because the outlet air is warm and humid.

With respect to the exhaust, measures must be put in place to account for damp air that may form ice in cold surroundings.

3.6 Service liquid requirements

Only water-based liquid may be used as service liquid.

For operating conditions where there is a risk of ice formation in the service liquid system, a suitable anti-freeze must be used.

4 INSTALLATION AND START-UP

4.1 Securing the pump



If the tolerance for securing the pump is not observed, there is a risk of damage.

The pump must be installed on a stable foundation, which must be level and stable, so that the pump is not twisted or exposed to a profile distortion.

The pump must be anchored with M16 foundation bolts on all four legs, which must be tightened to 180 Nm. (A)

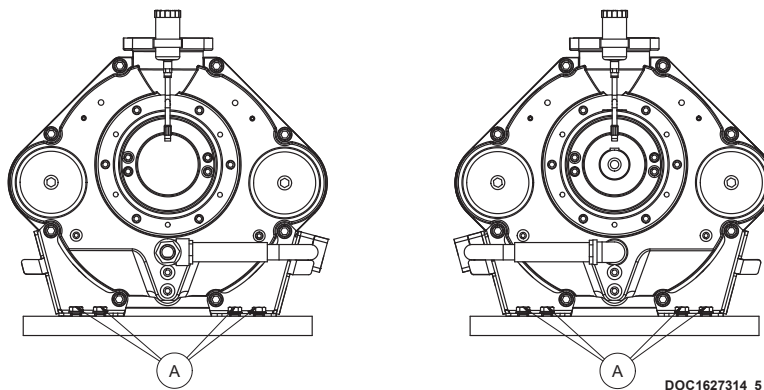

4.2 Connections to the pump



- Check for foreign objects in the pump and physical damage on pump.
- Gaskets to be handled with highest degree of caution.
- Gasket and sealing surfaces must be cleaned before assembly.

Immediate before connecting the pipes, remove protective covers. Connection of the pump's suction and pressure pipe connections must be made with a gasket in between. (C)

The M16 bolts must be tightened to 180 Nm. (B)

In order to prevent tensions in the pump, the pipe connections (A) must be tensionless while tightening the bolts.

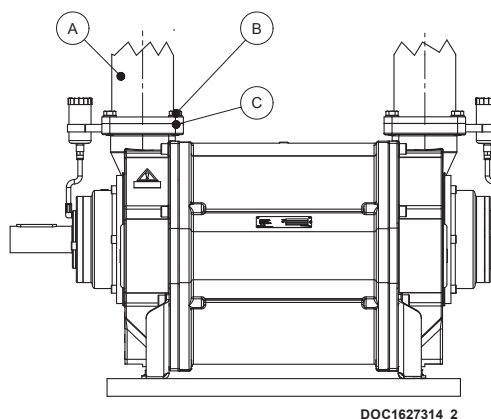

4.3 Connecting the service liquid

The service liquid connection must be established on both ends of the pump to ensure optimal working conditions for the pump, and so that the mechanical shaft seals are lubricated by the service liquid.

A valve is to be mounted on the connection, which can open and close the service liquid supply independently of the pump.

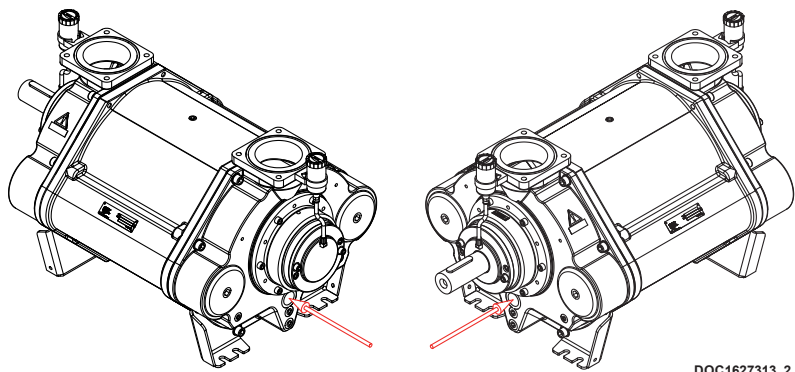

4.4 Transmission

The pump can be connected to direct or belt transmission. For belt transmission, it must be ensured that the permissible radial force is not exceeded. See specifications.

4.5 Prior to start-up



- Do not start the pump without service liquid, as this will damage the mechanical shaft seals.
- Do not start the pump if it is completely filled with service liquid.
- Do not start the pump before the grease cartridges have been activated, as this can damage the pump. (if equipped)
- Stop the pump immediately if the rotational direction does not correspond to the directional arrow.
- A failure to follow the above guidelines may result in damage to the pump.

Activating the grease cartridges

Turn the knob in NDE clockwise to position 12.
Turn the knob in DE clockwise to position 12, if bearing housing operating temperature is below 90°C, otherwise turn the knob to position 6.

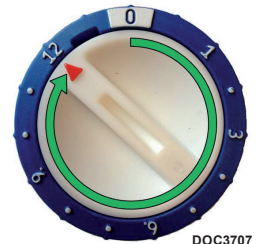

DOC3707

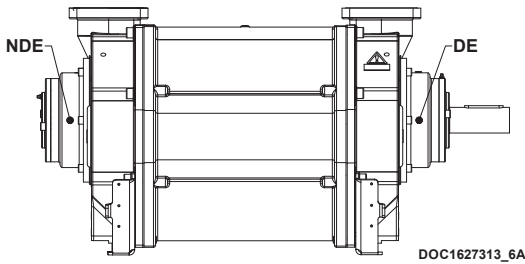

DOC1627313_6A

4.6 Direction of rotation

Check the direction of rotation by briefly starting the pump.

The direction of rotation of the rotor must correspond to the direction arrow!

Below left, a right-side pump is shown which has a clockwise direction of rotation. (CW)

Below right, a left-side pump is shown which has a counter-clockwise direction of rotation. (CCW)

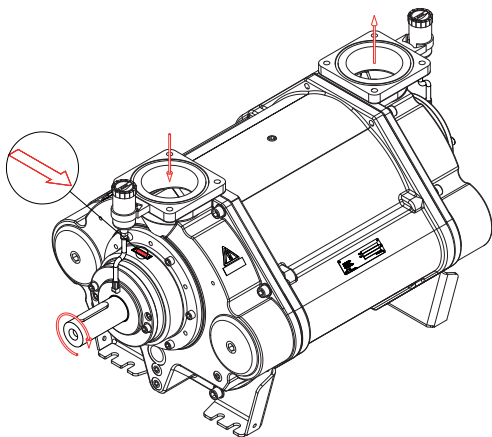

DOC1627317_1

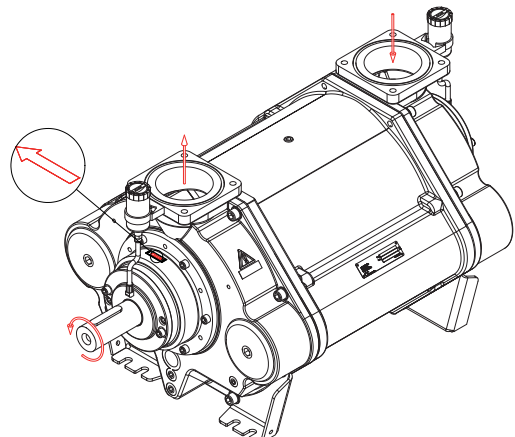

DOC1627317_2

5 RECOMMENDED SERVICE, MAINTENANCE AND INSPECTION INTERVALS



A failure to observe the inspection intervals described in table below may result in damage to the pump.

Section	Operation	Interval
5.1	Drain liquid separator to remove contaminants	Weekly
5.2	Check grease cartridges (if equipped)	Weekly
5.3	Lubrication of bearings	Monthly
5.4	Inspection and cleaning of service liquid's supply pipe	Monthly

5.1 Draining the liquid separator

While the pump is stopped, the liquid separator must be drained to remove contaminants.

5.2 Check grease cartridges

If the pump is equipped with an automatic lubrication feature. It must be inspected and replaced as needed.

When the pump is commissioned for the first time, the cartridges must be activated by turning the arrow in the clockwise direction.

The cartridge is set to 6 or 12, which corresponds to an emptying time of 6 or 12 months. The cartridge must be replaced when empty.

It is only allowed to use automatic lubricator of type **LAGD 125/WA2**.



DOC3707

5.3 Lubrication of bearings



Over-lubrication of bearings may result in bearing failure! Do NOT exceed the amount of grease specified below!

The bearings must be lubricated with grease of type SKF LGWA2, once a month. It is recommended to lubricate the bearings while pump is running.

Pump	KM2200	KM2700
Drive end (DE)	10 g/mth*	11 g/mth*
Non drive end (NDE)	9 g/ mth	11 g/mth

* - In operating conditions where bearing housing exceeds 90°C, to be lubricated with 23 g/mth.

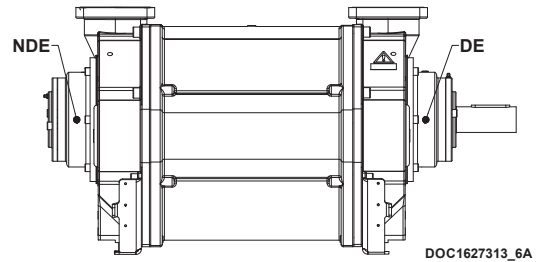

5.4 Inspection and cleaning of service liquid's supply pipe

The pipe connection between the liquid separator and pump must be inspected at least once a month, and any contaminants must be removed.

6 TROUBLESHOOTING

Problem	Cause	Effect	Corrective measure
The pump is unable to create a vacuum	<ul style="list-style-type: none"> • The pump is not receiving enough service liquid • The temperature of the service liquid is too high 	<ul style="list-style-type: none"> • Reduced output • The pump can become damaged during cavitation 	<ul style="list-style-type: none"> • Check the liquid supply • Stop the pump and wait until the temperature has dropped to a sufficient level, or lower the temperature of the service liquid inlet.
Power consumption too high during operation	<ul style="list-style-type: none"> • The pump is receiving too much service liquid 	<ul style="list-style-type: none"> • The pump can become worn 	<ul style="list-style-type: none"> • Check the liquid supply
The start-up power is too high	<ul style="list-style-type: none"> • Too much service liquid in the pump prior to start-up 	<ul style="list-style-type: none"> • Noise at start-up and possible overload of the power supply 	<ul style="list-style-type: none"> • Check the stop valves in the liquid supply for leakage
Noise during operation	<ul style="list-style-type: none"> • Cavitation 	<ul style="list-style-type: none"> • Severe damage to the pump and potential risk of breakdown 	<ul style="list-style-type: none"> • Increase the suction pressure or lower the temperature of the service liquid
Leakage from the bearing housing's drain holes	<ul style="list-style-type: none"> • Damaged shaft seal 	<ul style="list-style-type: none"> • Bearings may become damaged • Potential risk of explosive gas leak 	<ul style="list-style-type: none"> • Stop the pump and contact the manufacturer

7 SPARE PARTS

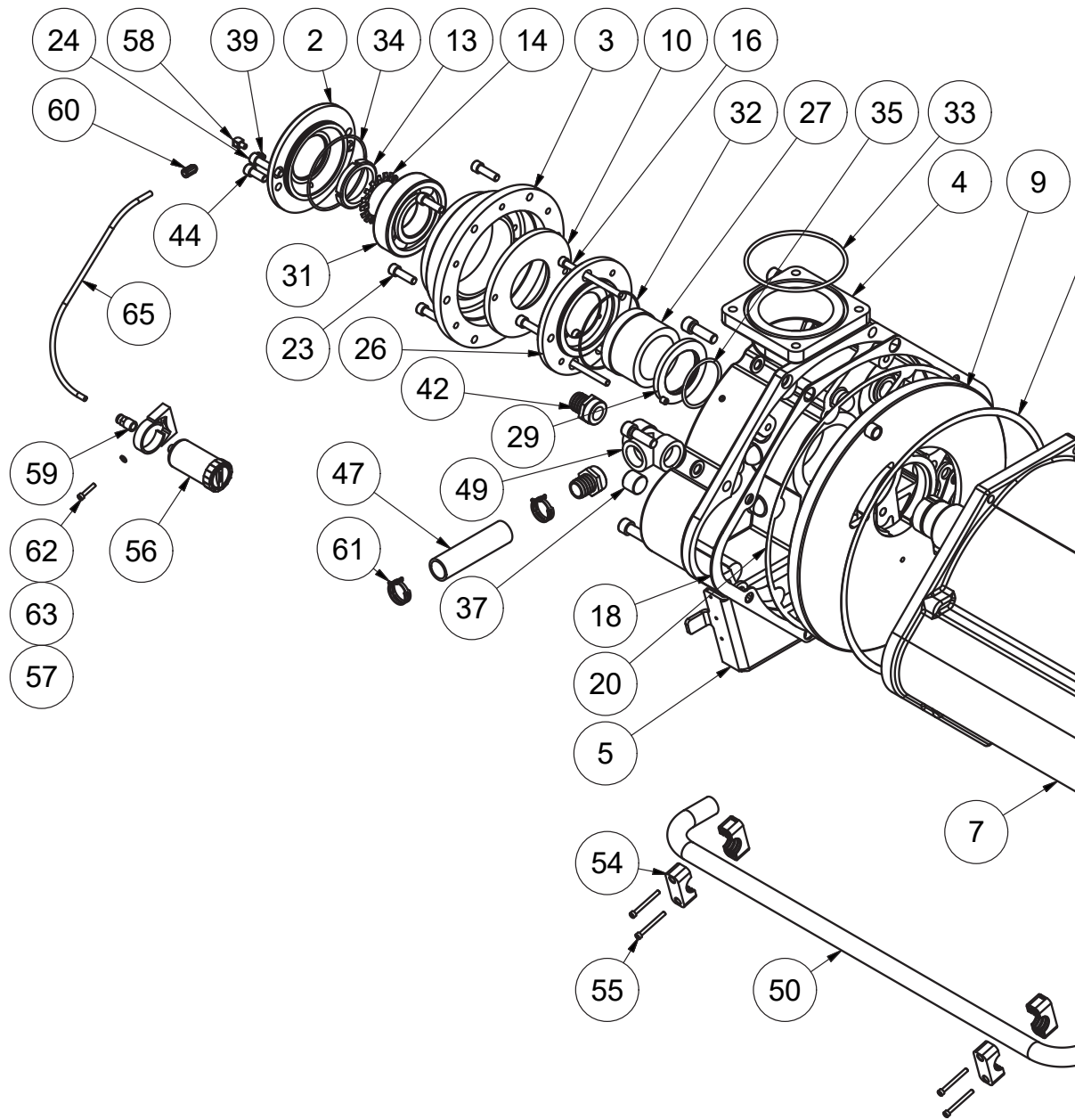

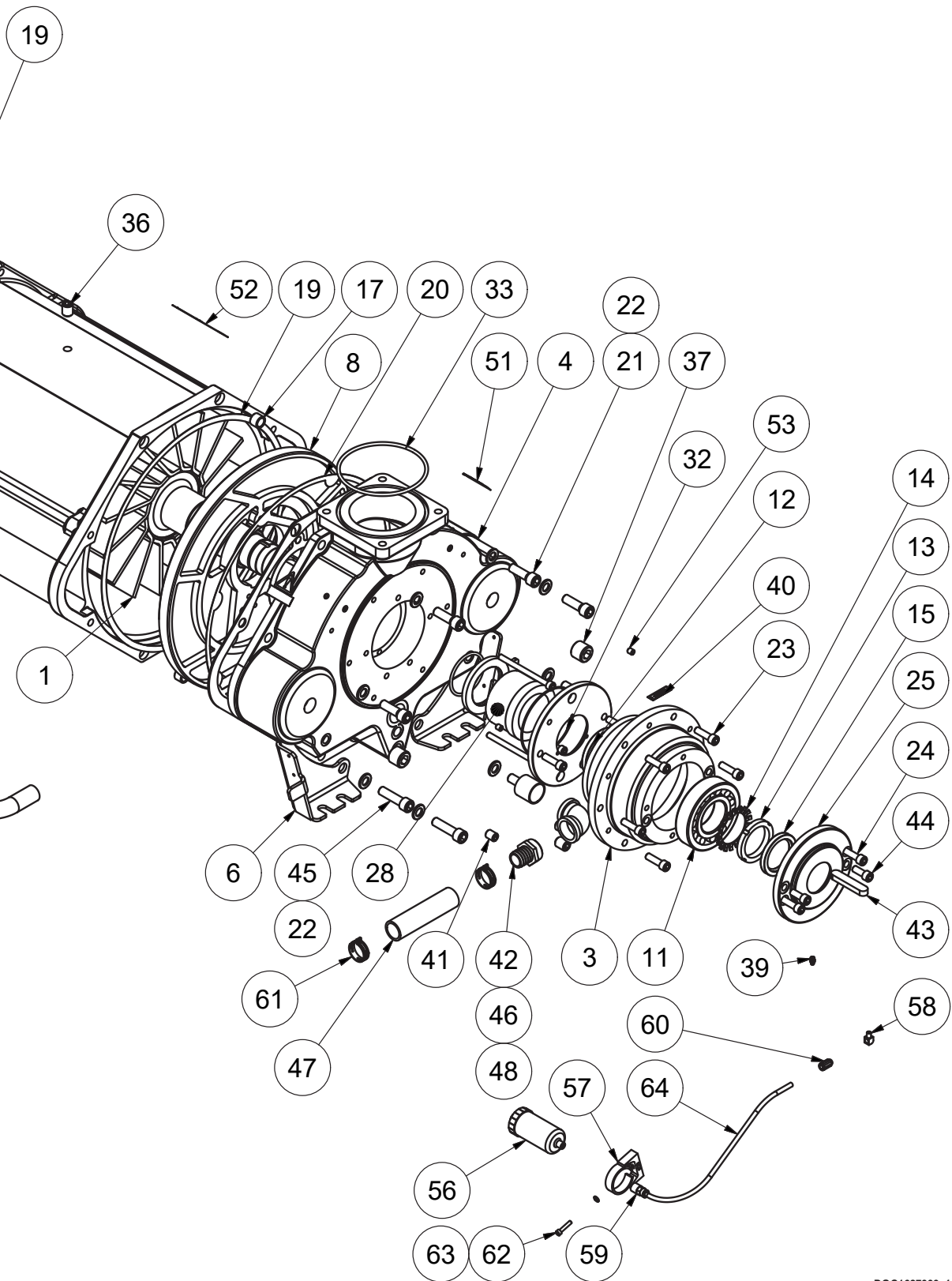

DOC1627339_1A

Pos.	Description	Qty.
1	Rotor	1
2	Bearing cover NDE	1
3	Bearing housing	2
4	Pump housing	2
5	Foot bracket	2
6	Foot bracket	2
7	Shell	1
8	Flow plate DE*	1
9	Flow plate NDE*	1
10	Rear cap	2
11	Roler bearing spherical 21313E ø65/140 x 33	1
12	Radial shaft seal 80x100x10 DIN 3760A Type CB/OA	2
13	Shaft nut KM 13 M65x2,0	2
14	Lock washer MB 13	2
15	Radial shaft seal 62x85x10 DIN 3760A Type CB/OA	1
16	M10x130 Allen screw DIN912 8.8FZB	6
17	Bushing D24/d18/L18 DIN1850	4
18	Gasket 3mm NBR	2
19	Gasket 0,5mm. Oakenstrong	2
20	Gasket	2
21	M16x50 Allen screw DIN912 8.8 FZB	8
22	M16 washer 17/30x3 DIN 125B FZB	16
23	M12x40 Allen screw DIN912 8.8FZB	16
24	M12x55 Allen screw DIN912 8.8FZB	4
25	Bearing cover DE	1
26	Retainer	2
27	Mechanical shaft seal NBR OT80-AB	1
28	Mechanical shaft seal NBR OT80-AB	1
29	Stop ring	2
31	Ball bearing 6313	1
32	O-ring 134x2,5 NBR70	2
33	O-ring 160x6 NBR70	2
34	O-ring 129,77x3,53 NBR70	1
35	O-ring 80x5 NBR70	2
36	Plug 1/2" Original	5
37	Plug 1" DIN 906	4
39	Grease nipple M8x1,25 H1**	2
40	Direction arrow	1

* -See section 1.3 for configuration of pump.

**-Optional. Not equipped as standard.

Pos.	Description	Qty.
41	Plug 3/8"	4
42	Hose nipple 1 1/4" x \varnothing 32	3
43	Parallel key 18x11x90 DIN6885A	1
44	M12x30 Allen screw	4
45	M16x60 Allen screw 8.8	8
46	5/4 elbow int/int	1
47	Hose \varnothing 32 PVC -850mBar(g)	2
48	Barrel nipple 1 1/4" x 38	2
49	Tee 1 1/4"	1
50	Service liquid supply pipe	1
51	Sticker Warning!	2
52	Identification plate 35x125 mm*	1
53	Plug 1/8" Original	4
54	Pipe support Dim. \varnothing 32	4
55	M6x60 Allen screw DIN912	4
56	Automatic lubricator LAGD 125/WA2**	2
57	Clamp for automatic lubricator**	2
58	Elbow 90deg M8x1,25k/M10x1**	2
59	Push-in nipple G1/4" internal thread**	2
60	Push-in nipple \varnothing 8-M10x1 external thread**	2
61	Clamp \varnothing 32-44 mm	4
62	M6x30 Allen screw DIN912**	2
63	M6 washer 6,4/12,5x1,6**	2
64	Hose \varnothing 8/ \varnothing 6mm**	0,415 m
65	Hose \varnothing 8/ \varnothing 6mm**	0,45 m

* -See section 1.3 for configuration of pump.

**-Optional. Not equipped as standard.

SAMSON PUMPS

Samson Pumps is the only company in the world to specialise exclusively in liquid ring vacuum pumps. Samson pumps are made in Denmark and used around the globe. We offer worldwide delivery, and we export to more than 80 countries around the world.

For over 40 years, our name has been synonymous with the strongest pumps for vacuum trucks and tankers. We constantly adapt our products to meet the changing needs of our customers. Today, it is not enough to simply produce a pump. Products must be refined so the customer can concentrate on what they do best. We therefore offer a wide range of standardised components that allow our customers to build vacuum systems without the need for specialist in-house expertise.

Strength and durability are our hallmarks! We have often heard from customers that our pumps are working in many years, and in most cases without the need for maintenance or repair. This emboldens us to say that we have the strongest program of pumps on the market.